

KSTAR

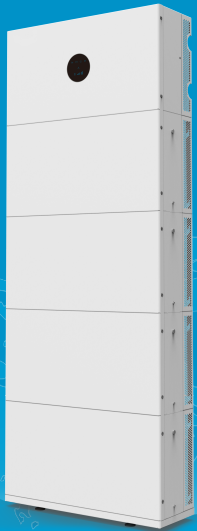

INSTALLATION, OPERATION &
MAINTENANCE MANUAL

E3.68KS-D22 / E5KS-D22 Series

Hybrid Inverter

Table of Contents

1	ABOUT THIS MANUAL	3
1.1	Purpose	3
1.2	Intended Audience	3
1.3	Conventions	4
1.4	Change History	4
2	SAFETY INSTRUCTIONS	5
2.1	Limitation of Liability	5
2.2	Warning Signs	6
2.3	Battery Safety	7
2.4	Before Installation	10
2.5	Installation Safety	12
2.6	Operation Safety	14
2.7	Maintenance Safety	17
2.8	Disposal Safety	18
3	SYSTEM INTRODUCTION	19
3.1	Product Overview	19
3.2	Model	21
3.3	System Topology	21
3.4	Operating Modes	22
3.5	Supported Grid Types	22
4	INVERTER APPEARANCE	23
4.1	External ports on the inverter	23
4.2	Battery Pack Appearance	25
4.3	LED Indicators	26
4.4	Storage & Unpacking	27
4.5	Storage Requirements	28
5	MECHANICAL INSTALLATION	31
5.1	Location Requirements	31
5.2	Installation Tools & Required Cables	32
5.3	Handling of Equipment	33
5.4	Mechanical Installation	33
6.	SYSTEM WIRINGS	37
6.1	Electrical Connection	38
6.2	PE Cable Connection	38
6.3	DC (MPPT) connection	40
6.4	Energy storage system Expansion Overview:	43

6.5	AC Connection (Grid & EPS).....	44
6.6	CT/Meter Connection.....	46
6.7	DRM Connection	48
7	SYSTEM COMMISSIONING.....	50
7.1	Pre-power Check	50
7.2	Power ON Procedure	50
7.3	Install Protective Covers.....	51
7.4	App Commissioning	51
7.5	KSTAR Sync APP.....	52
7.6	Download APP	52
7.7	System Operation.....	52
8	OPERATION & MAINTENANCE	65
8.1	Inspection Checklist for Users.....	65
8.2	Inspection Checklist for Professional Personnel.....	66
8.3	Troubleshooting	66
9	TECHNICAL DATA.....	77
9.1	Hybrid Inverter	77
9.2	Battery Terminal Input /Output	78
9.3	PV Input.....	78
9.4	Grid Terminal Input / Output	79
9.5	EPS Load Terminal Output.....	79
9.6	Battery Pack.....	79
10	QUALITY ASSURANCE.....	81
11	ABBREVIATIONS.....	82
12	APPENDIX: DEFINITION OF DVC	83

Legal Statement

© Shenzhen KSTAR New Energy Company Limited. 2024. All rights reserved.

All material appearing on this manual (“content”) is the property of Shenzhen KSTAR New Energy Company Limited (“KSTAR New Energy”). Distributing, copying, or forwarding any content to a third party or uploading any content to third-party platforms (such as publicly accessible websites) without prior permission of KSTAR New Energy is expressly prohibited.

Trademarks and Permissions

KSTAR and other KSTAR trademarks used in this manual are owned by Shenzhen KSTAR New Energy Company Limited.

All other trademarks or registered trademarks are the property of their respective owners.

Software License

KSTAR New Energy reserves all rights to the firmware and software. You may not use any of the data in the firmware or software for commercial purposes in any way.

Reverse engineering, decompiling, disassembling, adapting, implanting, or other derivative operations on the equipment are prohibited, as are researching the design and implementation of the equipment, obtaining the source code, infringing on intellectual property rights in any way, and disclosing the results of any performance tests.

Disclaimer

Before transporting, storing, installing, using, and/or maintaining the equipment, read this manual, adhere strictly to its prescriptions, and pay attention to the labels on the equipment.

In this manual,

- “Equipment” refers to the hardware products, firmware, software, components, spare parts, and/or services to which this manual relates.
- “You” or “your” refers to an individual or a legal entity transporting, storing, installing, using, and/or maintaining the equipment.

In addition to paying proper attention to content in this manual labelled DANGER, WARNING, CAUTION, and NOTICE, you shall comply with relevant international, national, or regional standards, and industry practices. KSTAR New Energy shall not be liable for any damages resulting from violations of safety requirements or safety standards for the design, manufacturing, and use of the equipment.

KSTAR New Energy is not responsible for damage, personal injuries, death, and/or loss of or damage to property caused by use outside the scope of the conditions, technical specifications, or instructions provided in this manual.

Transport, storage, installation, use, maintenance, and all other operations shall comply with applicable laws and regulations, standards, and specifications.

KSTAR New Energy shall bear no liability in any of the following circumstances:

- The equipment is damaged due to earthquakes, floods, volcanic eruptions, mudslides, lightning strikes, fires, wars or armed conflicts, typhoons, hurricanes, tornadoes, extreme weather, or other force majeure events.
- The equipment is used outside the scope of the conditions, technical specifications, or instructions provided in this manual.
- Installation and/or use do not comply with relevant international, national, or regional standards or regulations.
- The equipment is installed or operated by unqualified personnel.
- The equipment is operated in a manner not in accordance with the prescriptions of the instruction manual and safety labels.
- The equipment and/or software code is disassembled and/or modified without the permission of KSTAR New Energy.
- The equipment is damaged while being transported by you or a third party commissioned by you.
- The equipment is stored in conditions that do not meet the standards specified in this manual.
- In the course of operating or maintaining the equipment, you use your own materials and tools that do not meet the requirements of local laws, regulations, and standards.
- Damage is caused by you or a third party through negligence, willful misconduct, gross negligence, or mishandling, or for other reasons not attributable to KSTAR New Energy.

1 About This Manual

This manual contains important information on the transport, storage, installation, use, and maintenance of the equipment. Read this manual carefully before operation. You must use the equipment strictly in accordance with the instructions in this manual to prevent damage or loss to the equipment, persons, and/or property. Keep this manual for future reference.

1.1 Purpose

This manual is intended as:

- An introduction to a single -phase hybrid inverter (the E3.68KS-D22/E5KS-D22),and the BP48100P (F)1A-G2 lithium-ion battery pack.
- An installation and maintenance guide for qualified personnel and technicians working with the hybrid inverters.
- An operating guide for qualified personnel, technicians, and users of the energy management system (EMS) integrated in the hybrid inverter.

This manual does not include information on all the components in a photovoltaic system. For more information, visit www.KSTAR.com or the websites of the component manufacturers.





1.2 Intended Audience

The intended audience of this manual is:

- The qualified professional personnel and technicians who install, operate, and maintain residenti hybrid inverter that include an E3.68KS-D22/E5KS-D22 hybrid inverter, and/or the BP48100P (F)A-G2 battery pack.
- Users who need to view inverter parameters.
- System integration solution providers.

1.3 Conventions

The following symbols are used in this manual to highlight important information.

 DANGER	Indicates a hazardous situation that, if not avoided, will result in death or severe injury.
 WARNING	Indicates a hazardous situation that, if not avoided, could result in death or severe injury.
 CAUTION	Indicates a hazardous situation that, if not avoided, could result in minor or moderate injury.
NOTICE	Indicates information that is considered important but is not hazard related, typically used for activities that result in property damage, but no personal injury.
	Indicates an important tip that leads to the best results, but not safety or damage related.

1.4 Change History

Here is the change history of this manual.

Version	Date	Changes
1.0	2026-04	• Initial release.

2 Safety Instructions

All the safety instructions in this section help you transport, store, install, use, and maintain the equipment safely, so be sure to read and follow them. In addition to these safety instructions, you must comply with the requirements of international, national, or regional standards and regulations, and you are encouraged to follow industry best practices.

The equipment must be transported, installed, and maintained by trained professionals who fully understand how the equipment works, have sufficient training and experience in operating the equipment, and know the possible dangers and their levels. Trained personnel are those who have received relevant technical and safety training and have relevant experience. They know the possible dangers they may face when operating the equipment and how to take steps to minimize the dangers to themselves and others.

2.1 Limitation of Liability

KSTAR New Energy is not responsible, directly or indirectly, for any damage to the equipment or loss of property caused by the following:

- Disassembling and/or modifying the equipment, replacing parts, or modifying the software code without the permission of the manufacturer.
- Altering, repairing, and erasing serial numbers or seals by technicians not certified by the manufacturer.
- Installation and/or operation of the equipment by unqualified personnel.
- Installing the inverter in any way that does not comply with standards or regulations.
- Failure to comply with local safety regulations. For example, in Germany, equipment must comply with VDE certification and in Australia it must comply with SAA certification.
- Operation of the equipment in an environment with insufficient ventilation.
- Use not in accordance with the instruction manual, technical specifications, and/or any other instruction provided.
- Use of your own materials and tools that do not meet the requirements of local laws, regulations, and standards.
- Failure to follow standard maintenance procedures.
- Earthquakes, floods, volcanic eruptions, mudslides, lightning strikes, fires, wars, armed conflicts, typhoons, hurricanes, tornadoes, extreme weather, or other force majeure events.

Additionally, KSTAR New Energy is not responsible, directly or indirectly, for:





- Damage sustained during transportation, including paint scratches caused by friction inside the package during transportation, and damage sustained while being transported by you or a third party commissioned by you. You must file claims with the shipping or insurance company when the container and/or the package is unloaded and the damage is confirmed.
- Any other damage caused by you or a third party through negligence, willful

misconduct, or mishandling, or for other reasons not attributable to KSTAR New Energy.

2.2 Warning Signs

The warning signs and nameplates attached to the equipment contain important information to guide you in safe use of the equipment. DO NOT remove, obscure, or damage these signs. Make sure that these signs are always intact and fixed in their correct positions. If a warning sign is damaged, contact the manufacturer and have it replaced immediately by certified technicians.

You can see these warning signs attached to the equipment.

	<p>Indicates a hazardous situation that, if not avoided, can result in death or severe injury!</p>
	<p>Indicates that the inverter should NOT be touched or used for at least five minutes after it is turned off or disconnected, in order to prevent electric shock or personal injury.</p>
	<p>Indicates a hot surface. Contact can cause burns.</p>
	<p>Indicates that you should read the user manual for instructions.</p>

WARNING

After the equipment is unpacked,

- Check all the warning signs and nameplates on the equipment.
- If you find any damages to the warning signs and/or nameplates on the equipment, contact the manufacturer immediately and DO NOT install the equipment.

WARNING

Before disposal, make sure that all warning signs and nameplates are clearly visible and are not removed or obscured.

WARNING

When you instruct others in use of the equipment, and maintain and/or repair the equipment, follow these instructions to prevent inappropriate use or accidents caused by uninvolved persons:

- Place clear signs at the front and rear-level switches to prevent accidents caused by inappropriate switching.
- Place a warning sign or safety caution tape around the operating area.

2.3 Battery Safety

A rechargeable lithium-ion phosphate battery is used in the equipment. The battery complies with the provisions of “United Nations Recommendations on the Transport of Dangerous Goods, Manual of Tests and Criteria, Part III, Section 38.3”.

KSTAR New Energy shall not be responsible for:

- Damages to the battery caused by earthquakes, floods, volcanic eruptions, mudslides, lightning strikes, fires, wars, armed conflicts, typhoons, hurricanes, tornadoes, extreme weather, or other force majeure events.
- Direct damage caused by operation of the equipment in environments other than the intended operating environment. Indicators of inappropriate environments include, but are not limited to, excessively high or low operating temperatures, instability of the power grid, and frequent power outages.
- Damage, leakage, and/or rupture caused by inappropriate operation or failure to connect the battery pack in accordance with requirements.
- Damage caused by over-discharge of the battery due to the failure of operating personnel to promptly power up the battery after it has been connected to the system.
- Damage caused by your failure to accept the battery in time after installation.
- Damage caused by inappropriate parameters that you set.
- Accelerated battery capacity degradation caused by mixing of batteries, including, but not limited to, the mixing of batteries of different brands and mixing of batteries with different rated capacities.
- Battery damage caused by storing the battery in an unintended environment, such as in a humid, rain-prone environment.
- Loss of capacity or irreversible damage to the battery caused over-storage without recharging the battery in a timely manner.
- Damage caused by your or a third party’s failure to follow the requirements specified by the manufacturer, including, but not limited to, unauthorized relocation and installation of the battery packs.

KSTAR New Energy shall not be responsible for damage caused by:

- Frequent over-discharge of batteries caused by your inappropriate maintenance, on-site expansion, or long-term failure to fully charge.
- Lack of appropriate maintenance in accordance with the operating manual. Such battery maintenance should include, but is not limited to, regular checks of the battery terminal screws to verify tightness.
- Changing the battery usage scenario without the approval of the manufacturer.
- Unapproved connection of additional loads to the battery.
- Batteries exceeding the maximum storage life.
- Batteries exceeding the warranty period. Such batteries can pose hazards and it is not recommended that you continue to use them.

2.3.1 General Instructions

The chemical substances inside the battery are well sealed, so there is no physical danger of fire or explosion or chemical danger of hazardous material leakage at normal temperatures and pressure levels during handling. If the battery pack is exposed to fire, mechanical shock, decomposition, or increased electrical stress due to misuse, then leakage, release of harmful substances, and/or explosion can occur. The released substances can irritate the eyes, skin, and throat.

 DANGER

- Only trained professionals are permitted to handle leaking batteries.
- When handling leaking batteries, personnel must wear goggles, rubber gloves, gas masks, and protective clothing.
- When handling leaking batteries, personnel must first disconnect the equipment and then remove the leaking batteries.
- Batteries should be protected from the following:
 - Short circuit caused by live line maintenance or by shorting the positive and negative terminals of the battery.
 - Exposure to high temperature or heating equipment, such as direct sunlight, ignition sources, transformers, heaters.
 - Squeezing by an external force or immersion in water or other liquids.
 - Over-charging or forced over-discharging.
 - Exposing battery terminals to other metal objects.
 - The use of incorrect battery types.

 WARNING

- Batteries should be protected from the following:
- Malfunctions or short circuits caused by liquid entering the battery. Therefore, DO NOT install the battery pack under air conditioning outlets, ventilation vents, machine room outlet windows, water pipes, and other locations prone to water leakage.
 - Inverted, sideways, tilted, or stacked placement.
 - False connection of fastening screws of the copper row and/or the cable, which can cause excessive voltage drop or the generation of a large amount of heat at higher current, which could burn the battery.
-

2.3.2 Maintenance of Battery Packs

 **DANGER**

- DO NOT perform live line maintenance on the batteries to prevent short circuit.
- Use the specified type of battery during replacement.

 **WARNING**

- Do a regular check on the fastening screws of copper rows and/or cables. Make sure that they are tightened and free of rust, corrosion, or other foreign objects. If they are not, clean them.

2.3.3 Disposal of Battery Packs

 **WARNING**

- Before disposal, completely discharge the battery and consume the lithium metal inside the battery.
 - DO NOT treat unwanted batteries as ordinary waste.
 - DO NOT throw the battery pack into fire or place them in high temperature.
 - DO NOT dissect, pierce, or crush the batteries.
 - If a battery pack is deformed, broken, or leaking, discard it immediately regardless of how long it has been in storage.
-

2.4 Before Installation



- Follow the safety instructions in this manual to prevent personal injury and/or property damage.
- During transportation, a certified ABC fire extinguisher with a capacity of at least 2 kg must be with the equipment.
- Smoking is not permitted on or near the vehicle while loading or unloading.
- Before installation, make sure that the equipment is free of any electrical connections.
- Make sure that no water pipes are inside the wall on which the system is to be mounted.
- To prevent possible electric shock, make sure that the inverter is not damaged and that the inverter and all switches connected to it are set to the “OFF” position.
- Before installation, use a properly calibrated voltage meter to test the inverter to prevent personal injury or damage caused by a life-threatening voltage.
- The PV string exposed to sunlight can generate high voltage. Do these to prevent personal injury:
 - The operator must wear personal protective equipment before electrical connection.
 - Before touching DC cables, use a measuring device to make sure that the cables are not energized.
 - Read the safety instructions attached to the PV string and its manuals.
 - DO NOT connect the inverter to a PV string that requires positive or negative grounding.



WARNING

- DO NOT transport equipment in severe weather such as lightning, rain, snow, or winds of force 6 or higher.
- If there is a fire, evacuate the building or equipment area and ring the fire alarm. DO NOT enter a burning building or equipment area.
- Choose an appropriate and safe place to install the equipment. This place must meet these requirements:
 - Temperature: For the inverter and battery pack. See [Specifications](#).
 - Relative humidity: 0–95% (No condensation).
 - NO flammable or explosive materials.
 - NOT accessible to children.
 - NO salt hazards.
 - Sheltered from direct sunlight or severe weather.
 - NOT subject to strong vibration or electromagnetic fields.
 - Well ventilated
 - NOT a living area.
- A distance of at least 30 mm must be maintained between the cable and a heat generating device or the periphery of a heat source area to prevent deterioration and/or breakage of the cable insulation caused by high temperature.
- DO NOT install the equipment that is infiltrated by moisture.
- DO NOT install the equipment with damaged enclosure and exposed to moisture.



CAUTION

- Only qualified personnel are permitted to transport the equipment.
- Loading, unloading, installation, removal, and transportation of inverters and battery packs must be accomplished by two or more persons to prevent personal injury caused by accidental falling equipment.
- If lifting tools are used to lift the equipment, make sure that no one passes or stays under the equipment.

NOTICE

- Before installation, do a regular check and maintenance on the tools.
-

2.5 Installation Safety



- To avoid personal injury caused by the high voltage inside the equipment:
 - Use special insulated tools for wiring.
 - Read the warning signs on the equipment and follow their instructions.
 - Follow the safety instructions in this manual and other documents provided.
 - Only trained professionals are permitted to install the equipment.
 - Only qualified personnel are permitted to disassemble the safety features and to service the equipment.
 - Only the personnel who have the special operation qualification required by national or local authorities are permitted to work in special scenarios such as electrical operation, work at heights, and operation of special equipment.
 - Only KSTAR-approved professional personnel are permitted to replace the equipment or spare parts (including software).
 - DO NOT power up the equipment before the installation is completed and confirmed by trained professionals.
 - Avoid direct contact with the power supply equipment, as well as indirect contact through wet objects. Prevent other conductors from coming into contact with the power supply equipment. Measure the voltage at the point of contact before you touch any conductor surface or terminal, so as to avoid electric shock.
 - Use appropriate measuring tools to make sure that the electrical parameters of the equipment meet the requirements. To prevent electric arcs or shocks, make sure that the connection and use of the equipment comply with the specifications.
-



WARNING

- DO NOT install equipment in severe weather such as lightning, rain, snow, or winds of force 6 or higher.
- If there is a fire, evacuate the building or equipment area and ring the fire alarm, or call the emergency services. DO NOT enter a burning building or equipment area.
- It is recommended that you install the inverter vertically, not inverted, horizontal, tilted forward or backward, excessively tilted, or tilted sideways.
- When tightening screws or bolts on products or terminals with tools, tighten to the specified torque to prevent damage to the equipment. The manufacturer shall not be responsible for such damage.
- DO NOT touch the equipment surface when the equipment is in operation. The housing gets hot, and touching it can result in burns.
- The cables used in the PV system must be of the right size, firmly connected, and well insulated.
- Before connecting the DC connector to the inverter, check the positive and negative terminals of the PV string and make sure that no error occurs before inserting the DC connector into the DC terminal.
- During the installation of the inverter, make sure that neither the positive nor the negative terminal of the PV string is shorted to ground, to prevent damage caused by AC/DC short circuit of the inverter.



CAUTION

- To prevent uninvolved persons from approaching the equipment, place highly visible warning signs or set up safety caution tape around the equipment.
- DO NOT remove the equipment protection.
- DO NOT ignore the danger, warning, caution, and notice text in the manuals and on the equipment.

NOTICE

- The wiring process must follow the regulations of the local grid and the safety instructions for the PV string.
-

2.6 Operation Safety



DANGER

Follow the safety instructions in this manual to prevent personal injury and/or property damage.

- The person who operates the equipment must have necessary knowledge of the equipment, including the equipment components and how they work.
 - The person who operates the equipment must have necessary knowledge of this manual.
 - Only qualified personnel are permitted to disassemble the safety features and to service the equipment.
 - Keep persons other than those operating the equipment away from the equipment.
 - DO NOT operate the equipment in an environment where explosions can occur, or where the relative humidity is high.
 - When the equipment is in operation,
 - DO NOT open the inverter and the battery packs.
 - DO NOT wipe the equipment with a wet cloth.
 - DO NOT touch the housing of the equipment.
 - DO NOT plug or unplug connectors on the inverter.
 - To avoid electric shock, DO NOT touch any terminals of the inverter.
 - To avoid electric shock, DO NOT disassemble any parts of the inverter.
 - To avoid burns, DO NOT touch any hot parts of the inverter, such as radiator.
 - To avoid electric shock, DO NOT connect or disconnect a PV string or a component of a PV string.
 - To avoid fatal electric shock, DO NOT touch the DC conductors or energized electrical parts of the inverter. When PV arrays are exposed to sunlight, they can generate life-threatening DC voltage. This voltage can be present in DC conductors and in the energized electrical parts of the inverter.
 - To avoid electric shocks and burns caused by possible arcs, DO NOT disconnect the DC connector from the inverter under load.
 - Before operating the inverter or the battery packs, disconnect the inverter from all voltage sources as described in this manual.
 - DO NOT touch uninsulated cable ends.
-

-
- To prevent chemical burns caused by leakage of electrolyte or toxic gases from a damaged battery, operate the battery packs in accordance with the standard procedure. When the battery packs are operated in a standard manner, no leakage of electrolyte or generation of toxic gases can occur. However, if the battery packs are damaged or malfunction, it can leak electrolyte or generate toxic gases.

**WARNING**

- DO NOT operate equipment in severe weather such as lightning, rain, snow, or winds of force 6 or higher.
- DO NOT touch the equipment with wet hands.
- DO NOT put any heavy objects on the top of the equipment.
- DO NOT damage the equipment with sharp objects.

**WARNING**

External protective earthing terminal shall meet at least one of the following requirements:

- When the cross-sectional area of the earthing cable is $\geq 10\text{mm}^2$ (copper) or $\geq 16\text{mm}^2$ (aluminum), it is recommended that both the external protective earthing terminal and the AC side earthing terminal are grounded.
- When the cross-sectional area of the earthing cable is $< 10\text{mm}^2$ (copper) or $< 16\text{mm}^2$ (aluminum), ****ensure that**** both the external protective earthing terminal and the AC side earthing terminal are grounded.

If alternative earthing methods comply with local standards and relevant safety regulations, the connection may be performed according to such standards and regulations. Our company shall not be held liable for any consequences that may arise therefrom.



CAUTION

- To prevent uninvolved persons from approaching the equipment, place highly visible warning signs or set up safety caution tape around the equipment.
- DO NOT move the inverter when it is connected to the battery packs.
- Secure the inverter to prevent tilting.
- During the operation of the equipment, if any risks are found that may lead to personal injury or equipment damage, stop the operation immediately, report to the person in charge, and take effective steps.
- During the operation of the inverter, make sure that neither the positive nor the negative terminal of the PV string is shorted to ground, to prevent damage caused by AC/DC short circuit of the inverter.

NOTICE

- In the event of exposure to the electrolyte, immediately flush the affected area with water and seek immediate medical attention.
-

2.7 Maintenance Safety



DANGER

- Follow the safety instructions in this manual to prevent personal injury and/or property damage.
- Only trained professionals are permitted to maintain the equipment.
- Only qualified personnel are permitted to disassemble the safety features and to service the equipment.
- Keep persons other than those operating the equipment away from the equipment.
- Wear personal protective equipment (PPE), including protective gloves and protective shoes.
- DO NOT begin maintenance work on the equipment until it is turned off and fully discharged.
- Before maintenance, disconnect the AC circuit breaker from the grid and check the inverter status. If all the inverter indicator lights are off, do nothing and disconnect the DC switch at night. If the inverter indicator is on, disconnect the DC switch directly.
- After the inverter is powered down for five minutes, use testing equipment to check the voltage of the bus capacitor and of the capacitors in the battery terminal input and make sure that there is no voltage.
- To avoid burns, DO NOT operate the equipment immediately after shutdown. After the equipment cools down, wear protective gloves to operate the equipment.



WARNING

DO NOT maintain equipment in severe weather such as lightning, rain, snow, or winds of force 6 or higher.

- To avoid electric shock, DO NOT touch the power grid or the contacts and terminals inside the equipment that are connected to the grid.
- Use a standard voltmeter to check the grid. DO NOT touch the grid before you make sure that there is not voltage.
- To prevent or to minimize potential damage caused by moisture, DO NOT repair or maintain the equipment in a wet environment.



CAUTION

- To prevent uninvolved persons from approaching the equipment, place highly visible warning signs or set up safety caution tape around the equipment.
-

NOTICE

- If the paint on the inverter housing falls off or rust appears, repair it in a timely manner. Otherwise, the use of the inverter may be affected.
 - To avoid damaging the inverter, DO NOT use cleaning agents to clean the inverter. The manufacturer shall not be responsible for such damages.
 - DO NOT open the inverter (excluding the cable box) and replace the components inside without the permission of the manufacturer.
-

2.8 Disposal Safety



DANGER

- Only trained professionals are permitted to discard the equipment.
-



WARNING

- Before disposal, make sure that all warning signs and nameplates are clearly visible and have not been removed or obscured.
 - To prevent property damage and personal injury, dispose of equipment in accordance with local regulations and standards.
-

3 System Introduction

3.1 Product Overview

The integrated residential storage solution combines Inverter, Battery, Smart Meter, and smart dongle to convert solar energy into electricity within a hybrid inverter, meeting household power demands. Energy IoT devices in the system monitor overall power conditions and manage electrical loads, enabling intelligent control of electricity for direct use, storage in Battery, or export to Utility grid.

1. Space-saving: The vertical stack design occupies less floor space compared to traditional equipment. It can be mounted close to the wall, making full use of corners or narrow aisles, saving approximately 20%-30% of floor space compared to conventional all-in-one units.
2. Modular expansion: Users can start with a basic capacity configuration based on current power needs, just like building with blocks. In the future, when additional loads are added to the household, the capacity can be linearly increased by simply adding stacked battery modules—without replacing the entire system. This effectively reduces initial investment and upgrade costs.
3. Easy installation: Standardized interfaces between modules enable plug-and-play operation, eliminating complex external wiring. This makes the installation process very fast, significantly reducing installation difficulty and labor costs.

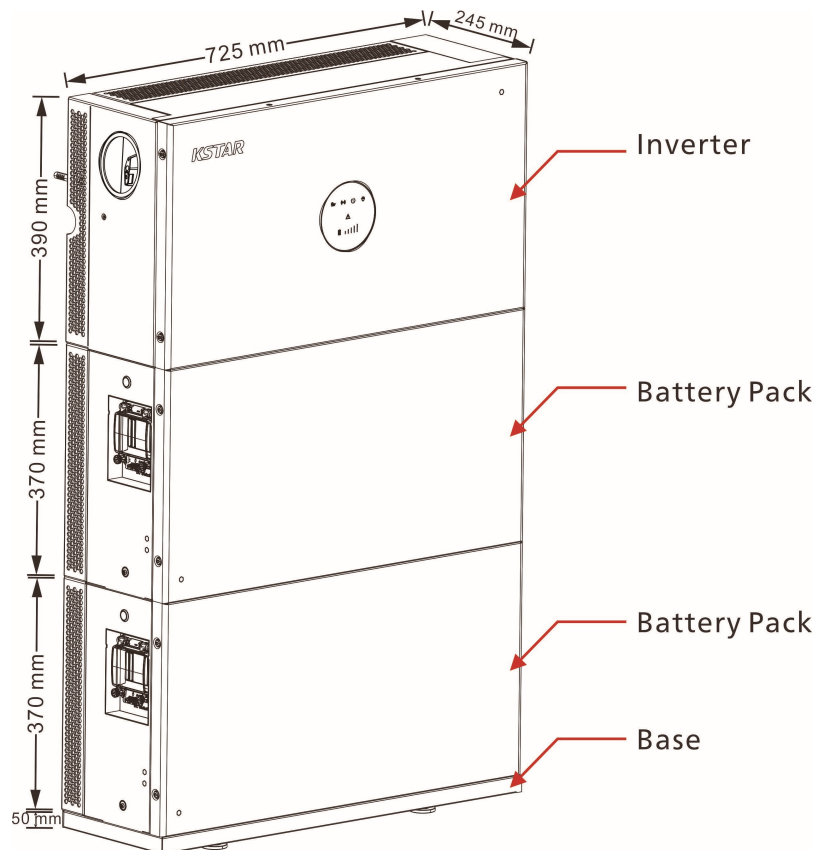

Battery Capacity Description

The ESS supports capacity expansion. A maximum of eight Energy Storage Modules can be installed.

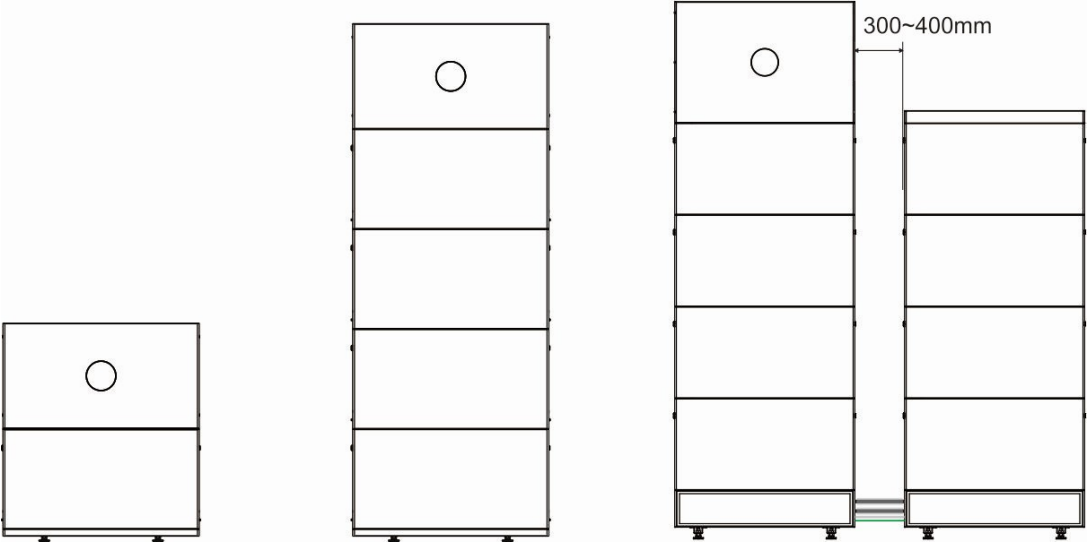
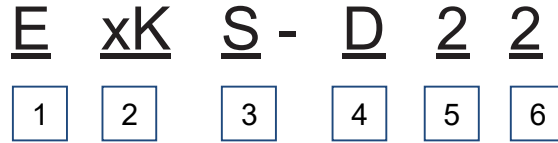

Figure 3-2 Capacity expansion with Energy Storage Modules

3.2 Model

3.3.1 Inverter Model

The hybrid inverter model is E3.68KS-D22/E5KS-D22 .



- 1 “E” means “energy storage system”.
- 2 “xK” indicates the rated output of the system. “3.68K” means 3.68 kW, “5K” means 5 kW.
- 3 “S” means “single-phase inverter”.
- 4 “D” means “Per MPPT current $\geq 20A$ ”
- 5 “2” means “2 MPPT”
- 6 “2” means “Generation 2”

3.3.2 Battery Pack Model



- 1 “BP” means the label “BATTERY PACK”.
- 2 “48” means the voltage of the battery pack 48V.
- 3 “100” means the battery capacity is 100Ah.
- 4 “P” means the battery packs are connected in parallel for multiple battery packs.
- 5 “F” means with a heating film.
- 6 “1A” means with EVE 3U cells, “2A” means with CATL 3U cells. , “3A” means with CATL 4.3U cells.
- 7 “G2” means the 2nd generation residential battery pack of KSTAR.

3.3 System Topology

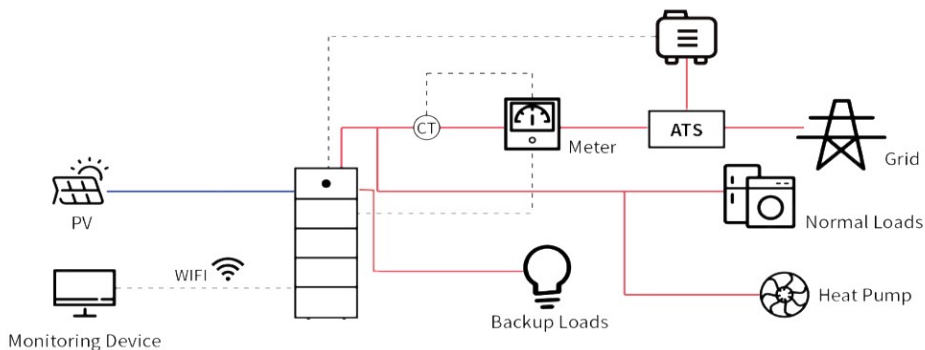

3.4 Operating Modes

Self-Consumption mode

- Self-Consumption mode is the basic working mode of the system.
- The power generated by the PV system supply the loads in priority; the excess power will charge the batteries, and then the remaining power will be sold to the utility grid. When the power generated in the PV system is insufficient, the battery will supply the loads in priority. If the battery power is insufficient, the load will be powered by the utility grid.

Peak-shift

- It is recommended to use Peak-shift mode in scenarios when the peak-valley electricity price varies a lot. Select Peak-shift mode only when it meets the local laws and regulations.
- For example, set the battery to charge mode during Valley period to charge battery with grid power. And set the battery to discharge mode during Peak period to power the load with the battery

BAT PRIORITY mode

- This mode is also known as the UPS mode, which is used in situations where a battery serves as a EPS power source. The battery only discharges when the grid power is down, helping to extend the battery's lifespan.
- If the battery is not fully charged, it will continue charging, and the charging power can come from either solar power or the utility grid. The goal is to keep the battery fully charged. During a power outage, the system operates off-grid to provide power to the EPS, which can be understood as the EPS function of a UPS.

3.5 Supported Grid Types

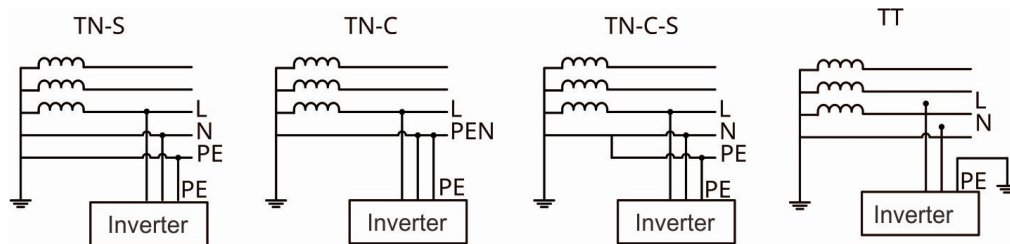

The grid supply methods supported include TN-S, TN-C, TN-C-S, and TT

When TT is used as the power supply technique for the power grid, the voltage between N and PE is required to be < 10 V.

4 Inverter Appearance

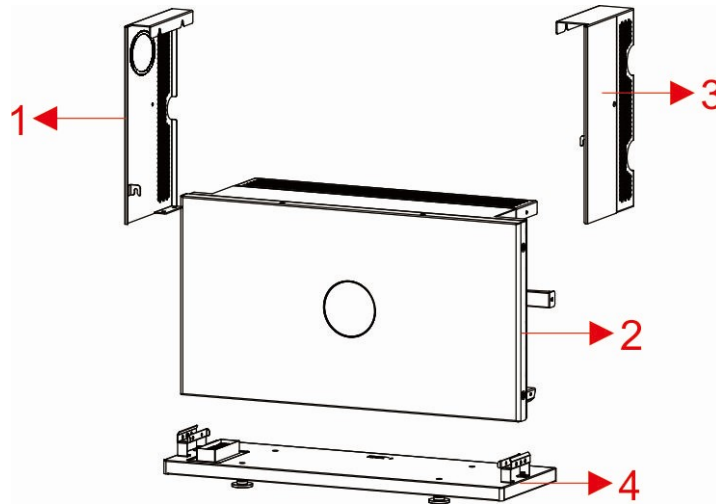

Item	Describe	Item	Describe
1	Left decorative panel	2	LED display panel
3	Right decorative panel	4	Floor stand support

Figure 4-1 the main components exploded diagram in the inverter packaging box

4.1 External ports on the inverter

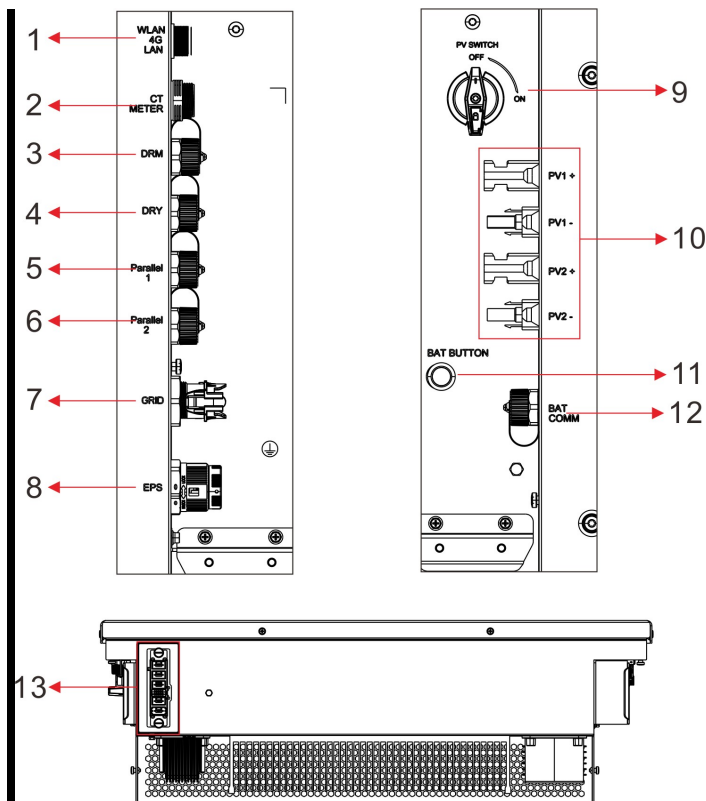

Figure 4-2 External Interface

Item	Describe	Item	Describe
1	WLAN/4G/LAN (DVC A)	2	CT/METER (DVC A)
3	DRM (DVC A)	4	DRY contact (DVC A)
5	Parallel1 (DVC A)	6	Parallel2 (DVC A)
7	GRID (DVC C)	8	EPS (DVC C)
9	PV SWITCH (DVC C)	10	PV1/PV2 (DVC C)
11	BAT BUTTON (DVC A)	12	BAT CAN (DVC A)
13	BAT connect (DVC C)		



Decisive voltage classification (DVC) identifies the minimum necessary level of protection for the circuit. For more information on the DVC of each port, see [Appendix: Definition of DVC](#).

4.2 Battery Pack Appearance

BP48100P1A-G2

4.2.1 Battery port information

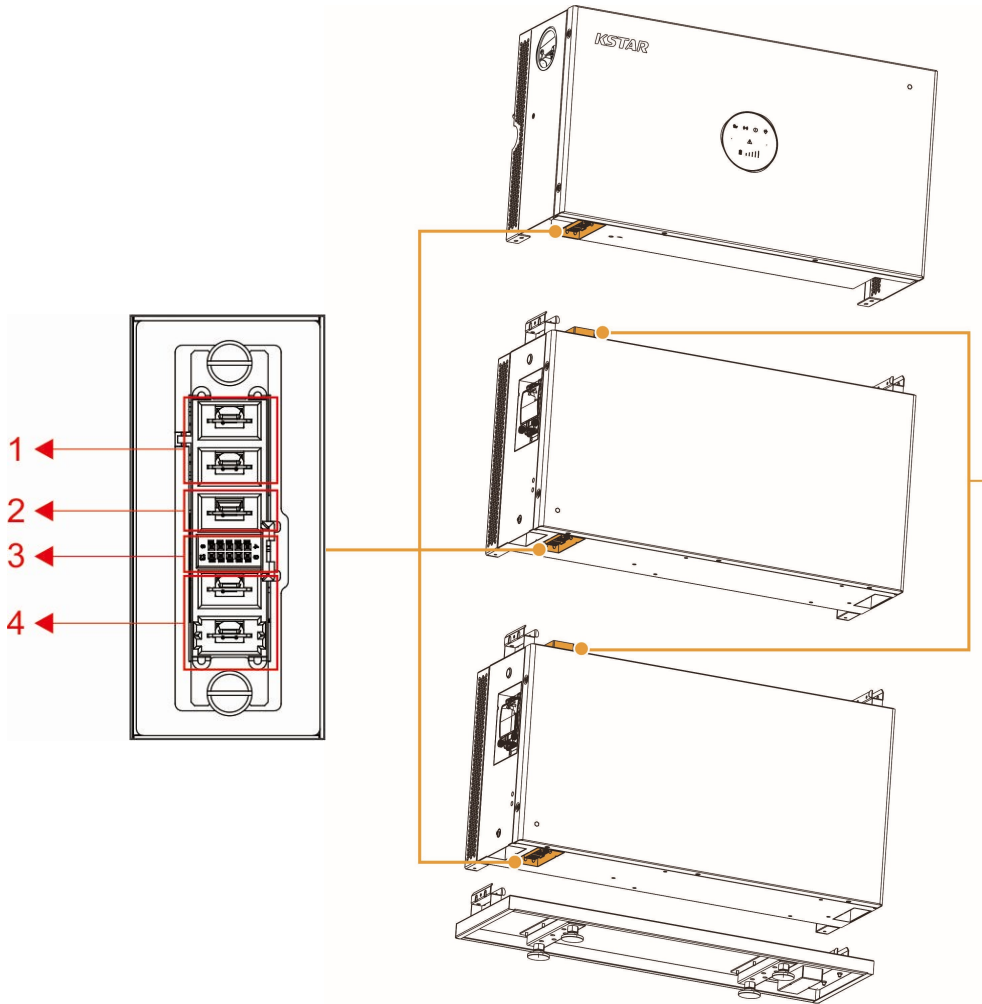

The battery power and signal connectors are in blind-inserted mode, so the communication was automatically connected after the battery packs and the inverter were assembled. BMS communication between Battery and Inverter through CANH & CANL terminals which are integrated below the interface.

Code	Describe
1	Battery-
2	Chassis ground
3	Communication interface
4	Battery+

4.3 LED Indicators



The inverter can be in six states shown in [Table 4-3](#).

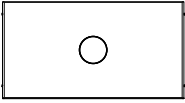
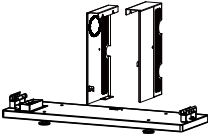
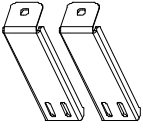
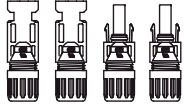

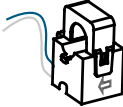
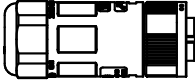
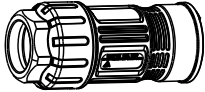
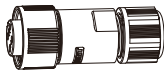
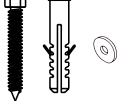

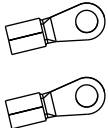
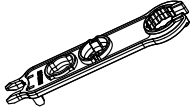

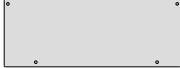

Table 4-3 Inverter States

Icons	Implication	Color	Status	Describe
	PV Indicator	Green	On	PV operating normally
			Flashing	PV connected but not operating
			Off	PV not connected
	Communication Indicator	Green	On	Monitoring backend connected and communication normal
			Off	Monitoring module not connected or communication abnormal
	Grid Indicator	Green	On	System in On-grid operation mode
			Flashing	System in bypass mode
			Off	System in initialization, standby, off-grid, fault, commissioning, or upgrade mode
	Off-Grid Indicator	Green	On	System in off-grid PV charging mode
			Off	PV off-grid charging not in progress
	Fault Indicator	Red	On	System fault
			Off	
	Battery Indicator	Green	On	Battery operating normally
			Flashing	Battery abnormal (alarm or BMS communication abnormal)
			Off	Battery shutdown or battery disconnected
	Battery SOC Indicator (Flashing during charging)	Green		≥80%
				≥60%
				≥40%
				≥20%
				≥5%
				<5%



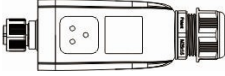
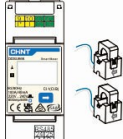

4.4 Storage & Unpacking

4.4.1 Packing List

4.4.1.1 Hybrid Inverter

 <p>Inverter (packed and assembled with base)</p>	 <p>Base and Decorative Covers</p>	 <p>Mounting bracket</p>	 <p>PV terminals: 2x positive, 2x negative</p>
 <p>M4x12 Bolt (6 sets)</p>	 <p>CT Cable (10 m)</p>	 <p>AC EPS connector</p>	 <p>AC grid connector</p>
 <p>WiFi Connector</p>	 <p>2 screws, 2 rubber sleeves, 2 gasket (base and wall bracket)</p>	 <p>3x RJ45 Connector</p>	 <p>OT terminals</p>
 <p>PV connector tool</p>	 <p>Quick Installation Guide</p>	 <p>Positional Punch card</p>	 <p>1xChange-Over Switch(63A)</p>
 <p>CT/Meter Connector</p>	 <p>Data Logger (WiFi + Ethernet)</p>	 <p>DDSU666-Smart Power Meter (Optional)</p>	

4.4.1.2 Battery pack Components

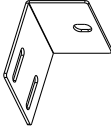
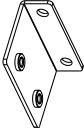
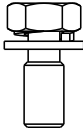
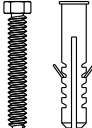
 <p>1×Battery pack</p>	 <p>2×Mechanical cover</p>	 <p>2×M6 Gasket</p>	 <p>2×M4*12</p>
 <p>2xWall Mounting Kit</p>	 <p>2xBattery Mounting Kit</p>	 <p>8×M5*12</p>	 <p>2×ST6.3*50 2×D10*50</p>

4.5 Storage Requirements

4.5.1 Storage Environment Requirements

It is recommended that you begin using the battery soon after delivery rather than store the battery pack for a long time. The maximum storage life of a battery pack is three years.

The intended storage environment of the battery pack should meet these requirements:

- Ambient temperature: 0°C to 35°C.
- Recommended storage temperature: 20°C to 30°C.
- Relative humidity: 0–95% (No condensation).
- Dry, ventilated, and clean area.
- No contact with corrosive organic solvents, gases, and other substances.
- No direct sunlight.
- More than two meters from any heat source.

WARNING

When storing a battery in its packaging, make sure that the packaging box is intact and that the battery is appropriately placed and stacked, and the above mentioned requirements are met.

4.5.2 Interval for Recharging Batteries

While in storage, batteries must be recharged at specified intervals.

Table 4.4 Recharge Batteries at Specified Intervals during Storage

Actual Storage Temperature	Interval
$-10^{\circ}\text{C} \leq T \leq 30^{\circ}\text{C}$	12 months
$30^{\circ}\text{C} < T \leq 45^{\circ}\text{C}$	8 months

For example, whether the battery is recharged every 8 months or every 12 months, it can only be recharged a maximum of three times within three years. If the battery has not been recharged within three years, it is recommended that the battery pack be discarded.

Lithium-ion batteries lose capacity during storage. After 12 months of storage at the intended storage temperature, the capacity generally falls irreversibly by 3–10%. Batteries with less than 100% capacity after storage cannot pass the discharge testing and acceptance testing.

4.5.3 Recharging a Battery

If a battery has not been charged for two weeks or more after a deep discharge, or the SOC of a battery is less than 50% after a long period of storage, the battery must be charged to 50%.

WARNING

Before charging the battery, check it for deformation, case damage, or leakage, and if you find any of these things, do not charge the battery.



If the SOC of a battery pack is not less than 50% after more than 12 months of storage, it is not necessary to recharge the battery.

NOTES

Prepare a cross screwdriver and insulated rubber gloves.

CAUTION

When you connect the power wires, wear insulated rubber gloves.

PROCEDURE

Step 1. Connect power cables to the battery charger correctly. The maximum number of battery pack connected parallel is 4.

Step 2. Press the battery “start key” for 1~3 seconds to start the battery pack. Check the LED on the battery “start key” is on.

Step 3. Turn on the battery charger.

Step 4. Set charging parameter on the battery charger.

Case #1, One battery pack is charged. Set the charge limited voltage 57.6V; Set the charge limited current 50A;

Case #2, Two ~ Four battery packs are charged. Set the charge limited voltage 57.6V; Set the charge limited current 100A;

Step 5. After the battery is charged, switch off the battery charger and press the battery “start key” for 1~3 seconds to switch off the battery pack.

5 Mechanical Installation

5.1 Location Requirements

5.1.1 Installation Environment Requirements

1. Do not install the equipment in a place near flammable, explosive, or corrosive materials.
2. The temperature and humidity at the installation site should be kept within the appropriate range.
3. Keep away from children.
4. High temperatures may exist on the surface of the equipment during operation to prevent burns.
5. Install the equipment in a sheltered place to avoid direct sunlight, rain, and snow.

Build a sunshade if it is needed.

6. The place to install the equipment shall be well-ventilated for heat radiation and large enough for operations.
7. Check the protection rating of the equipment and ensure that the installation environment meets the requirements. The inverter, battery system, and smart dongle can be installed both indoors and outdoors, but the smart meter can only be installed indoors.
8. Install the equipment at a height that is convenient for operation and maintenance, electrical connections, and checking indicators and labels.
9. The altitude to install the inverter shall be lower than the maximum working altitude of the system.

5.1.2 Installation Clearance Requirements



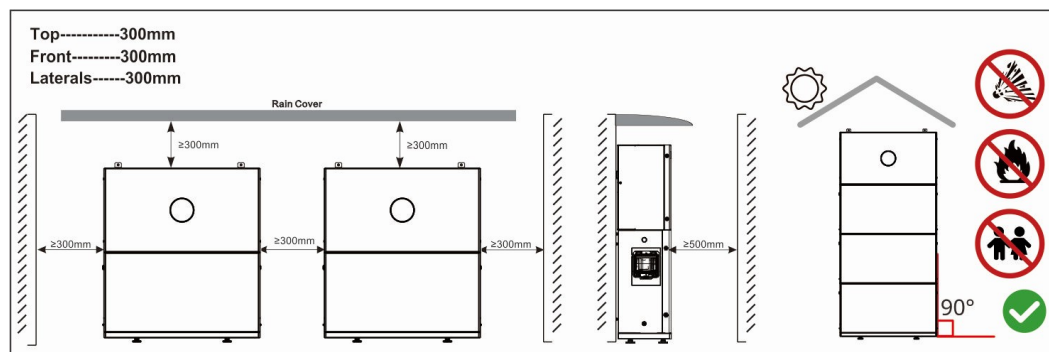









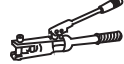
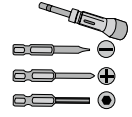

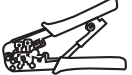

During installation, ensure that there is no other equipment (except related KSTAR equipment and awnings) or flammable or explosive materials around the ESS. Reserve sufficient space for heat dissipation and safety isolation.



5.2 Installation Tools & Required Cables

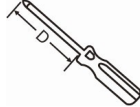

The following tools and cables are recommended when installing the equipment. Use other auxiliary tools and cables on site if necessary.

 Protective Goggles	 Protective Gloves Protective Shoes &	 Protective Mask	 Wire Clamp	 Torque wrench (M2/M3/ M4/M5/ M6)	 Leveling Instrument
 Cable Crimper	 Φ10mm Power Drill	 Φ 8mm Flat-head Screwdriver	 Multi-meter	 Rubber Mallet	 Tape Measure
 Marker Pen	 Wire Stripper	 M4(D ≥ 40mm) Cross Screwdriver	 AC Cable 1.EPS Wire (4 mm ²) 2.ON GRID Wire (6 mm ²)	 PV Wire (4 mm ² , max. Voltage 1,000 V)	 PE Cable(Cross section:4 ~6mm ²)

5.3 Handling of Equipment

CAUTION

Operations such as transportation, turnover, installation and so on must meet the requirements of the laws and regulations of the country or region where inverters are installed.

Move the equipment to the site before installation. Follow the instructions below to avoid personal injury or equipment damage.

1. Consider the weight of the equipment before moving it. Assign enough personnel to move the equipment to avoid personal injury.
2. Wear safety gloves to avoid personal injury.
3. Keep balance to avoid falling down when moving the equipment.
4. The battery system can be transported to the installation site by crane.
5. When moving equipment using a hoisting method, please use flexible slings or straps. The load-bearing capacity of a single strap must meet the following requirements:

(E3.68KS-D22/E5KS-D22) \geq 26KG;

(BP48100PF1A-G2) \geq 52KG;

5.4 Mechanical Installation

5.4.1 Handling of Equipment

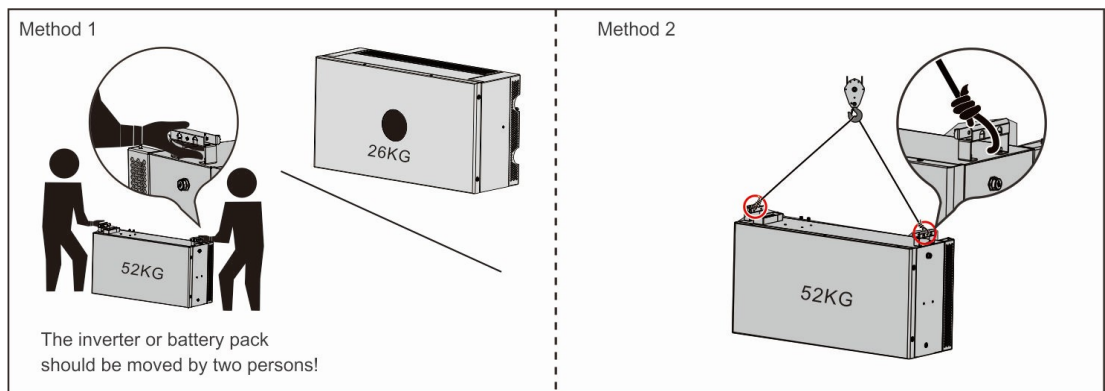

5.4.2 Remove the Base and Covers

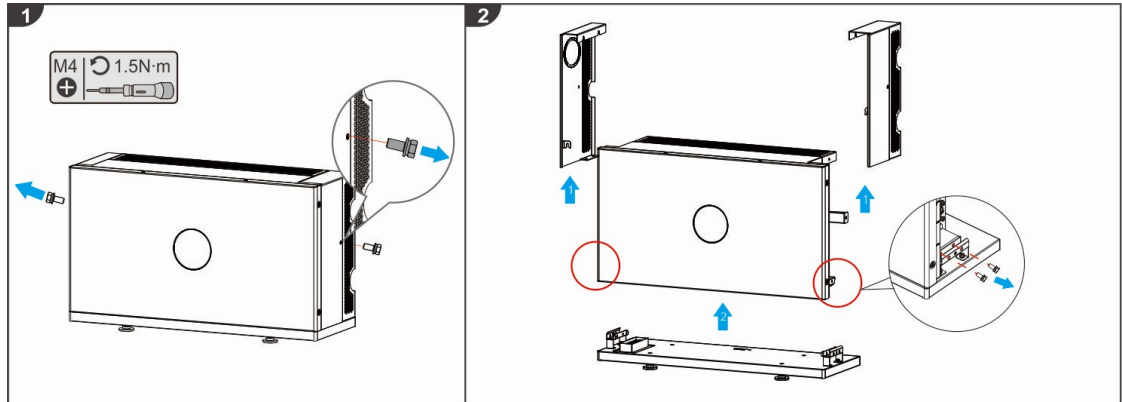

5.4.3 Install the Battery Pack

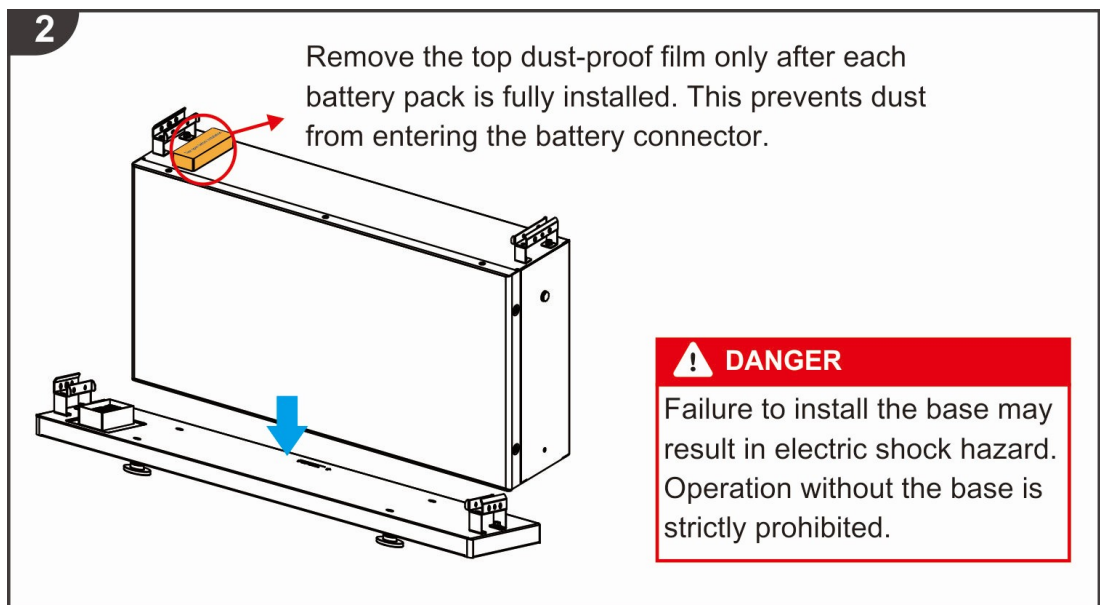
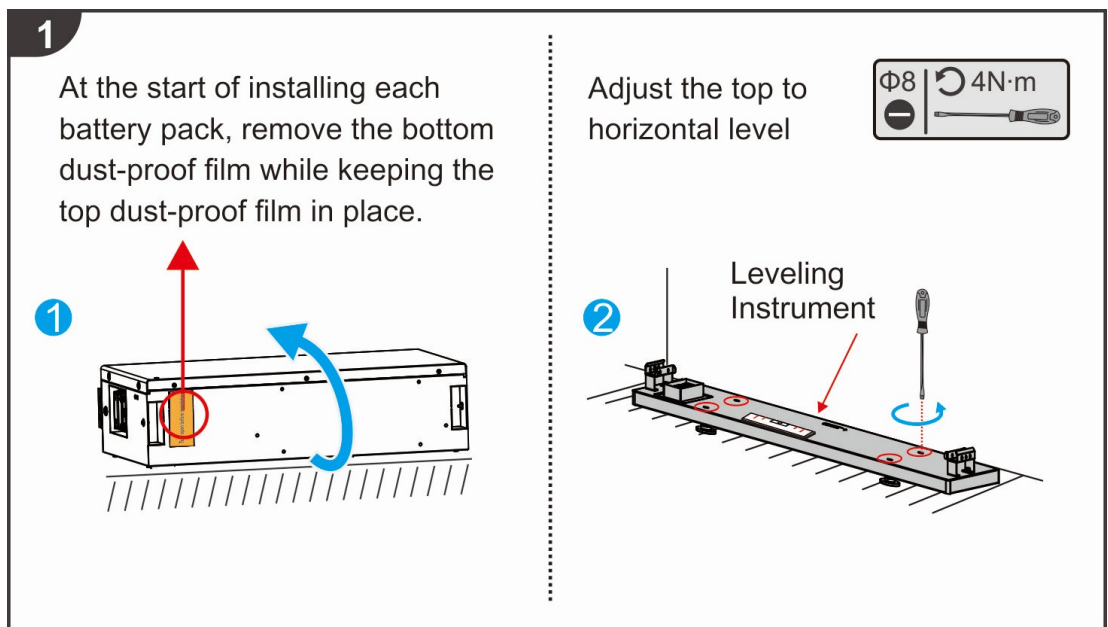

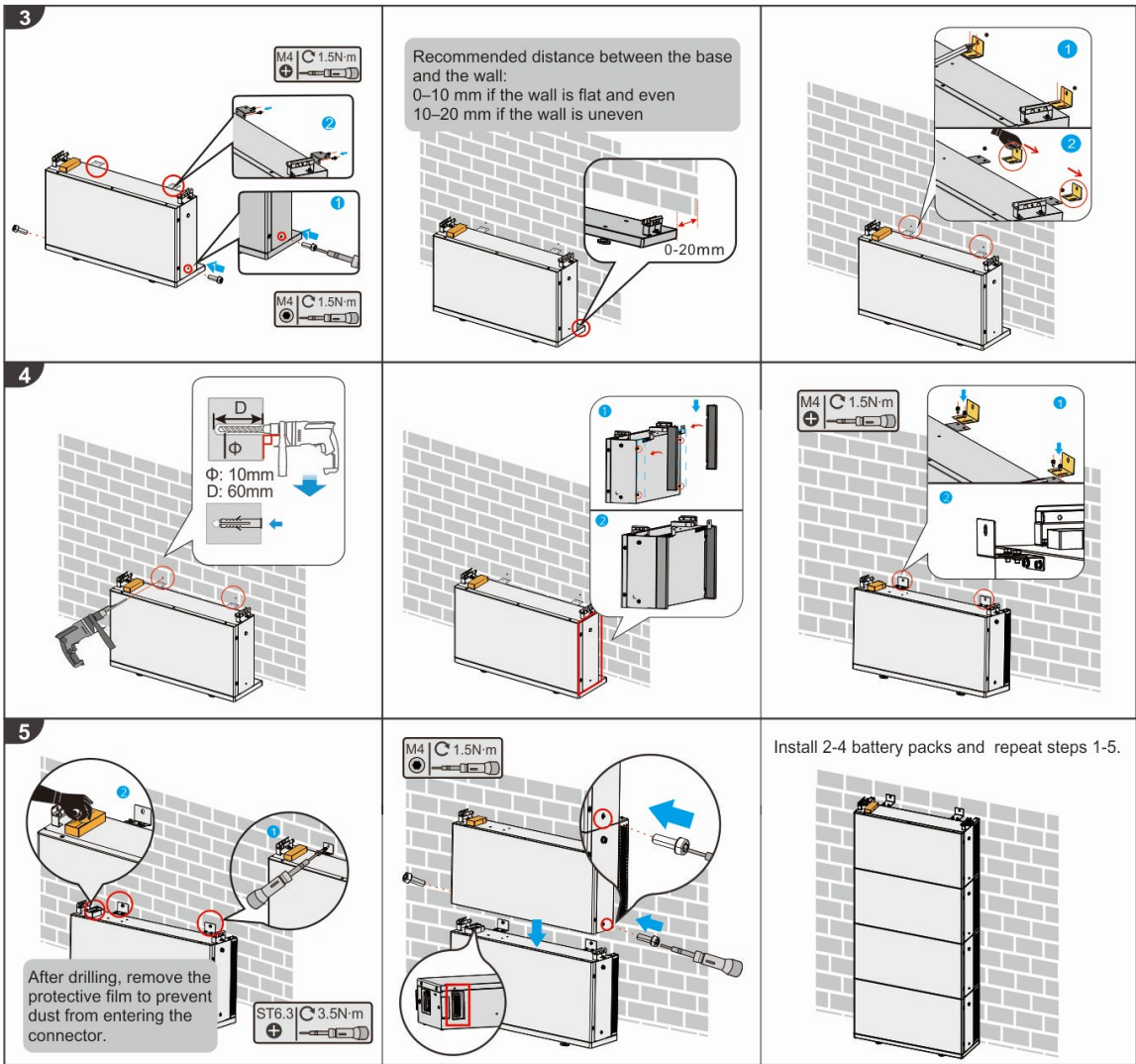

5.4.4 Install the Hybrid Inverter

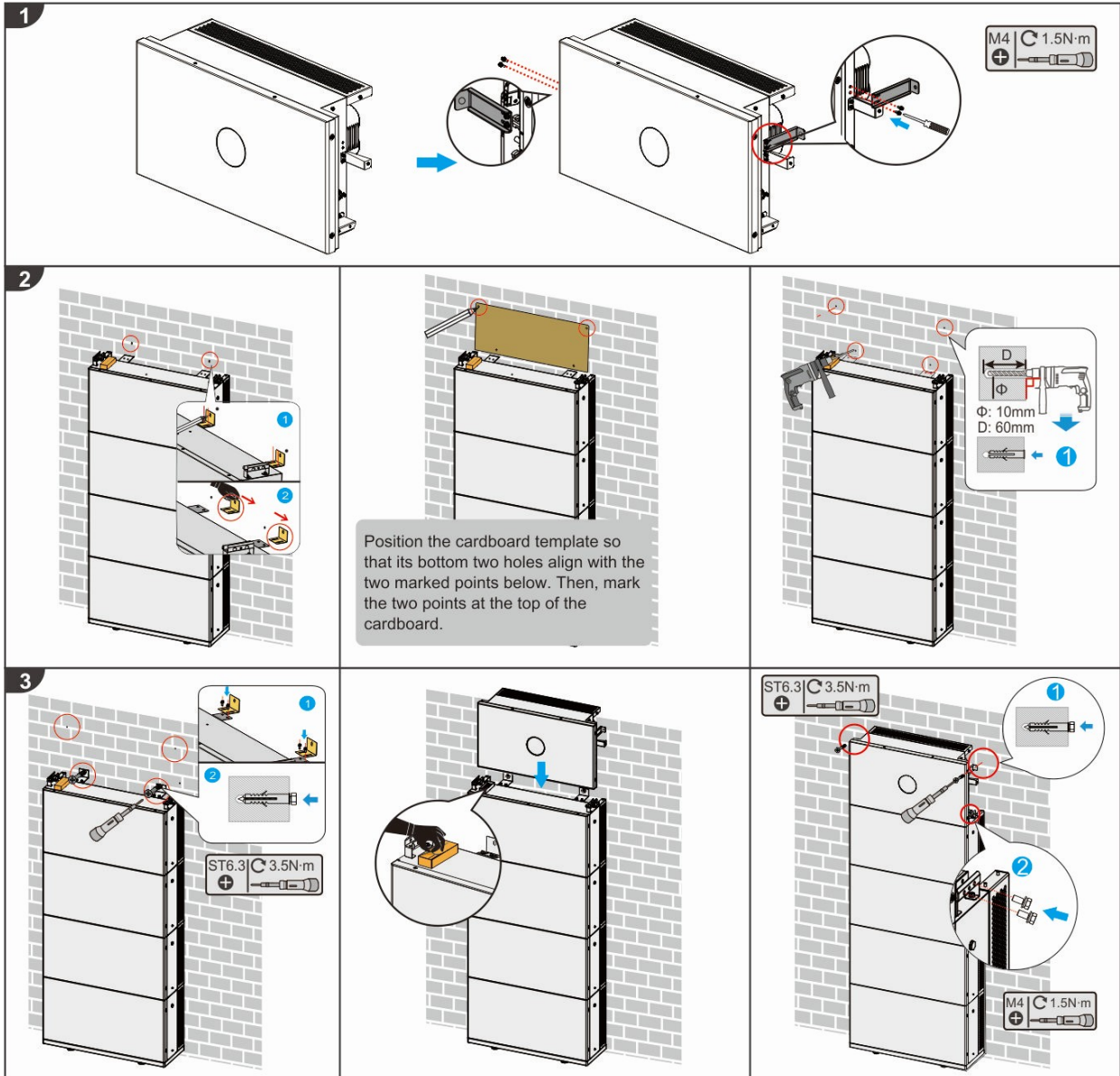

6. System Wirings

WARNING

- The installation, routing, and connection of cables must comply with local laws, regulations, and standard requirements.
- All operations during electrical connections, as well as the specifications of cables and components used, must comply with local laws and regulations.
- Before performing electrical connections, please disconnect the DC switch and AC output switch of the device to ensure it is powered off, Live operation is strictly prohibited, otherwise it may lead to DANGER such as electric shock.
- Cables of the same type should be bundled together and arranged separately from different types of cables. Intertwining or cross-arrangement is prohibited.
- If the cable is subjected to excessive tension, it may lead to poor connections. When wiring, please leave a certain length of cable before connecting to the inverter terminal ports.
- When crimping terminals, ensure that the conductor part of the cable is in full contact with the terminal. Do not crimp the cable insulation together with the terminal, otherwise it may cause the device to fail to operate, or after operation, due to unreliable connections leading to heating and other conditions that damage the inverter terminal block.
- This inverter has not been tested to Section 5 of AS/NZS 4777.2:2020 for multiple inverter combinations and/or multiple phase inverter combinations. Therefore, such combinations should not be used unless external devices are applied in accordance with AS/NZS 4777.1.
- For unused cable holes and ports (including communication ports), please use the dedicated terminals or plugs provided in the accessory box to reliably seal them. Otherwise, it may cause the following risks:
 - DANGER of electric shock: Open electrical ports may cause direct contact with live parts, leading to electric shock accidents.
 - Failure of protection: Open ports may allow dust, moisture, or foreign objects to intrude, which may lead to short circuits, fires, or equipment failures.



When performing electrical connections, wear personal protective equipment such as safety shoes, protective gloves, and insulated gloves as required. Only qualified personnel are permitted to perform electrical connection-related operations. The cable colors in the diagrams are for reference only; specific cable specifications must comply with local regulations.

6.1 Electrical Connection



N and PE wires are connected together in the distribution box.
To maintain neutral integrity, the neutral wires on the grid-connected side and off-grid side must be connected together, otherwise, the off-grid function cannot be used normally.
The following diagram is a schematic of the grid system for regions such as Australia and New Zealand:

The type A or B RCD (≥ 300 mA) must be installed on the EPS port of the system according to local regulations.

The type A or B RCD (≥ 300 mA) is supposed to be installed on the ON-Grid port of the system accordingly based on the local regulations.

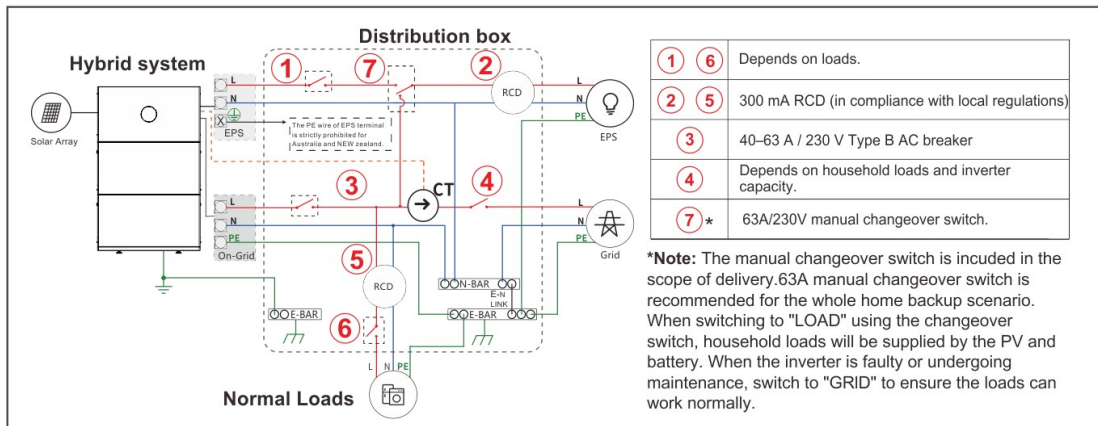

6.2 PE Cable Connection



WARNING

The Protection grounding of the chassis enclosure cannot replace the PE cable of the AC output port. when wiring, ensure that the PE cable at both locations is reliably connected.

To improve the corrosion resistance of terminal, it is recommended to apply silica gel or paint on the exterior of Grounding terminal for protection after completing the connection of Installation to PE cable.

When Installation equipment, the PE cable must be Installation first; when dismantle equipment, the PE cable must be dismantle last.

The grounding is integrated into the blind-mate connector and connected to the Inverter. The system is uniformly grounded through the Inverter, eliminating the need for separate grounding operations on the Battery during Installation.

NOTICE

- Recommended cables: a 10 AWG or 4-mm² cable for EPS connection and a 8 AWG or 6-mm² cable for ON GRID connection.
- Make sure that the resistance of the wires is lower than 1 Ω .
- Make sure that the grounding resistance, measured between the inverter case and the earth terminal of the distribution box, is less than 10 Ω .

DANGER

Before connection, make sure that the AC current breakers and the LOAD Switch in the distribution box are in the OFF state.

CAUTION

When connecting the wires to the connector, make sure that the phase wires and the earth wire are connected correctly.

CAUTION

Appliances such as air conditioners require sufficient time to equalize refrigerant gases within the circuit, so it takes at least two or three minutes to restart. If power supply is short-circuited and restored within a short period, it can cause damage to these appliances connected to the power supply. Before installing such appliances, make sure that the air conditioner has a time delay function to prevent such damage. In the absence of a time delay function, the inverter triggers an overload fault and cuts off the output to protect your appliances, but internal damage to appliances can sometimes still occur.

Procedure

Step 1 Crimp an OT terminal.



Avoid scratching the core wire when stripping a cable.

The cavity formed after the conductor crimp strip of the OT terminal is crimped must wrap the core wire completely. The core wire must make close contact with the OT terminal.

Wrap the wire crimping area with heat shrink tubing or insulation tape. The heat shrink tubing is used as an example.

Use a heat gun carefully to avoid heat damage to the equipment.

Step 2 Connect the ground point of the Energy Storage Control Unit to the external ground point.

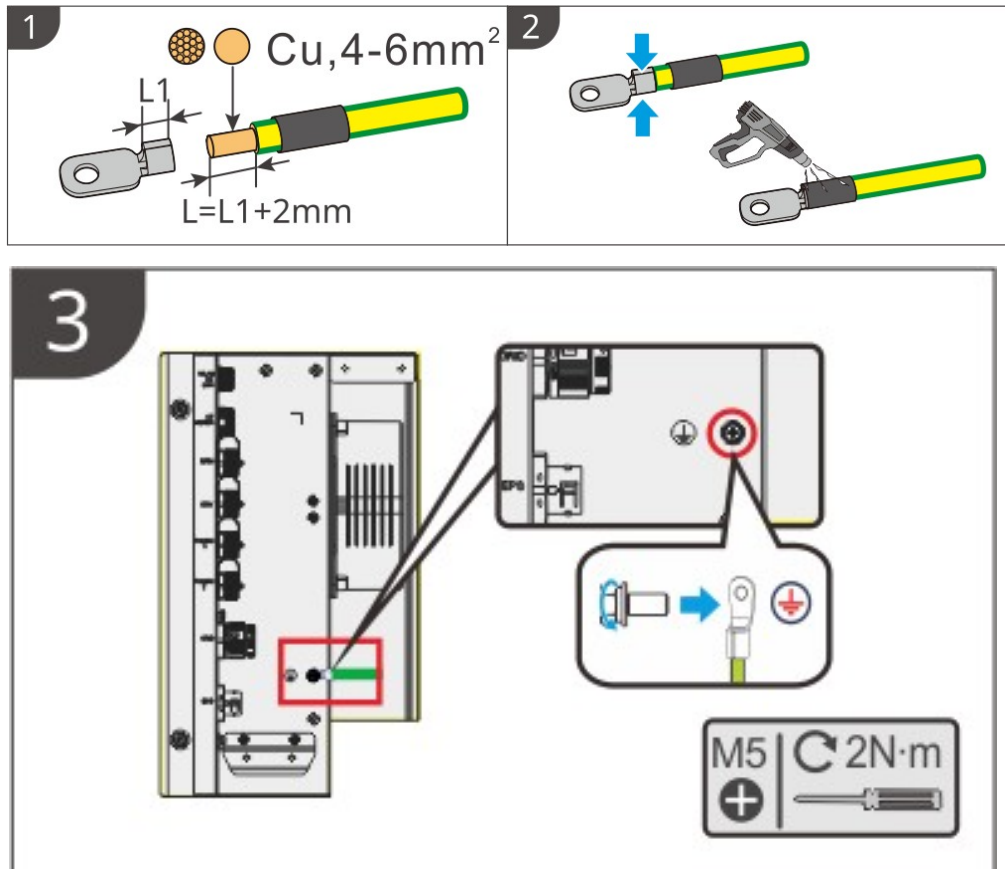

EARTH FAULT INTRODUCTION

Earth faults caused by insulation failure or accidental contact between live parts and ground that creates a low-resistance path for current to flow to earth, represent significant risks that require proper understanding and protective measures to mitigate their potentially dangerous effects.

EARTH FAULT ALARM

In the event of an earth fault, the inverter will display a fault code and push an alarm notification via the KSTAR Sync App.

6.3 DC (MPPT) connection

DANGER

The Protection grounding of the chassis enclosure cannot replace the PE cable of the AC output port. when wiring, ensure that the PE cable at both locations is reliably connected.

To improve the corrosion resistance of terminal, it is recommended to apply silica gel or paint on the exterior of Grounding terminal for protection after completing the connection of Installation to PE cable.

When Installation equipment, the PE cable must be Installation first; when dismantle equipment, the PE cable must be dismantle last.

The grounding is integrated into the blind-mate connector and connected to the Inverter. The system is uniformly grounded through the Inverter, eliminating the need for separate grounding operations on the Battery during Installation.

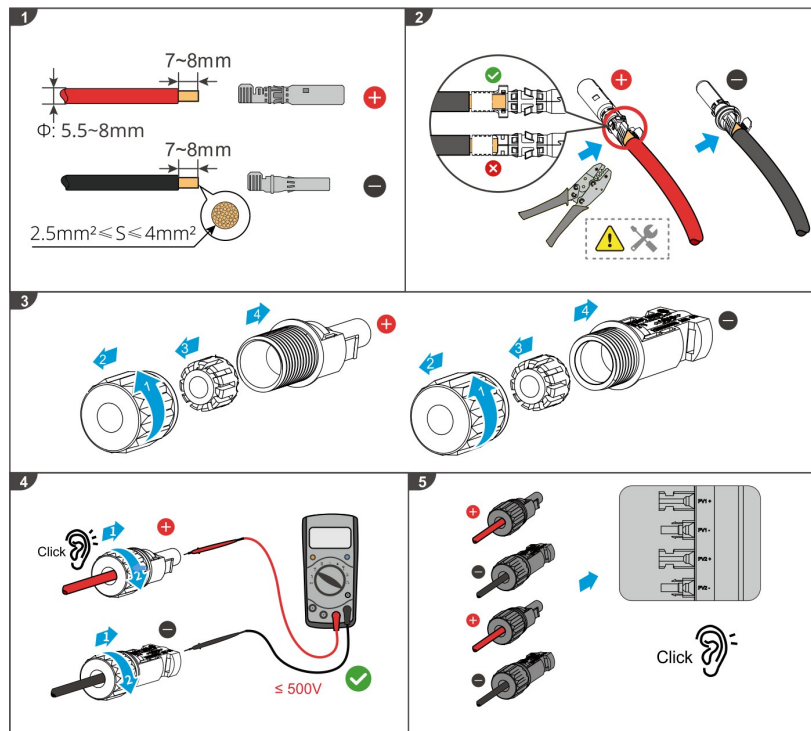

Do not connect the same PV string to multiple inverters, as this may cause inverter damage.

Before connecting the PV string to the inverter, confirm the following information. Failure to do so may cause permanent inverter damage, and in severe cases, may lead to fire resulting in personal injury or property loss.

1. Ensure the maximum short-circuit current and Max, Input Voltage for each MPPT are within the inverter's allowable range.
2. Ensure the positive pole of the PV string is connected to the inverter's PV+, and the negative pole of the PV string is connected to the inverter's Pv-



WARNING

PV string output does not support grounding. Before connecting the PV string to the inverter, ensure the minimum insulation resistance to ground of the PV string meets the minimum insulation impedance requirement ($R = \text{Max. Input Voltage} / 30\text{mA}$).

After completing the DC cable connection, ensure the cable connections are secure and not loose.

Use a multimeter to measure the positive and negative poles of the DC cable to ensure correct polarity (no reverse connection) and that the voltage is within the allowable range.

Use the Staubli MC4 positive and negative metal terminals and Dc connectors delivered with the product. Using other positive and negative metal terminals and DC connectors may result in serious consequences, such as cable overheating, burning, and module damage. The resulting device damage is not covered by the product warranty.

6.4 Energy storage system Expansion Overview:

A: cover

B: Base with parallel port in Installation

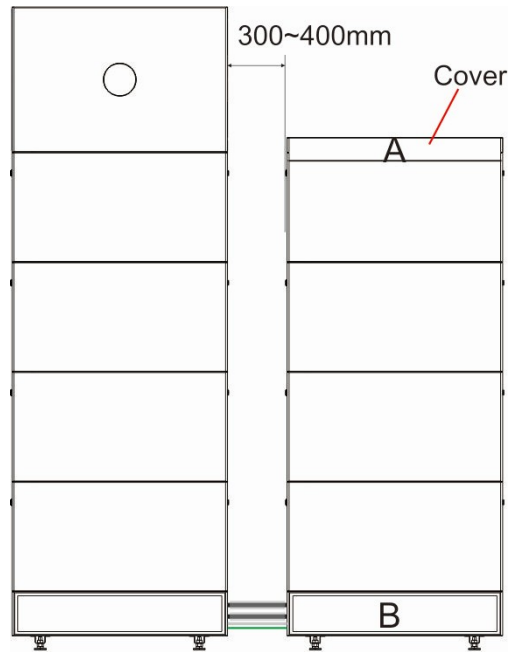

Eight Battery Packs

Battery system Expansion Harness Manufacturing Method

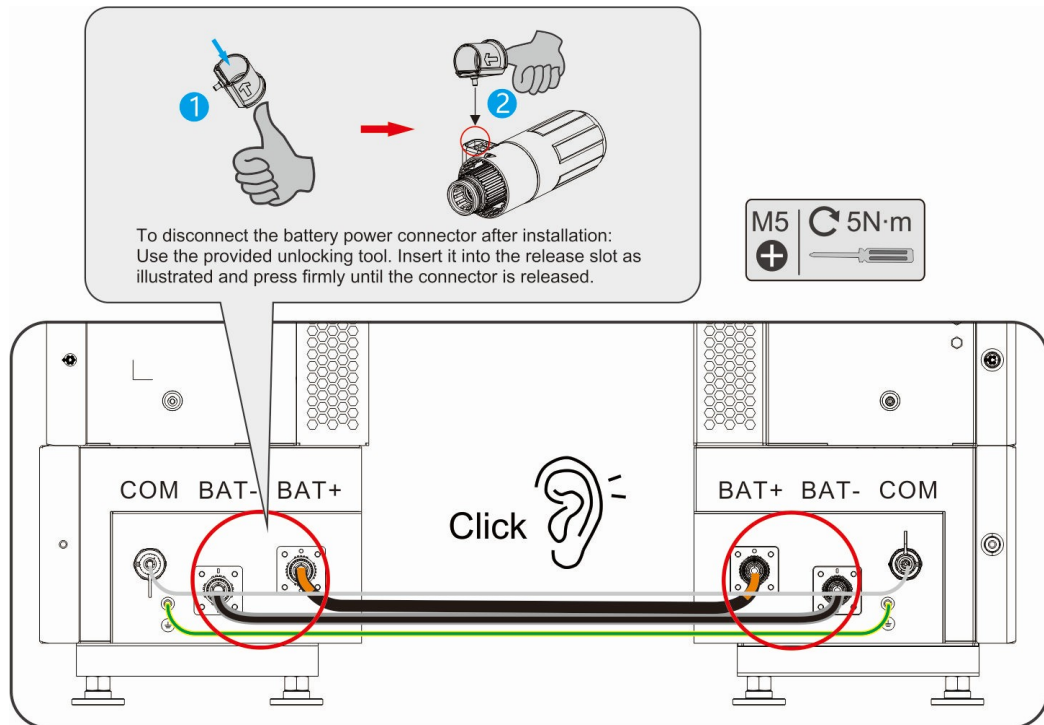

6.5 AC Connection (Grid & EPS)

WARNING

The inverter integrates a Residual Current Monitoring Unit (RCMU) internally to prevent the residual current from exceeding the specified value. When the inverter detects a leakage current greater than the permissible value, it will rapidly disconnect from the grid.

During wiring, ensure the Ac cables fully match the "EPS" and "ON-GRID" grounding terminals of the AC terminal block, Incorrect cable connection will cause equipment damage.

Ensure the wire cores are fully inserted into the terminal connection holes with no exposed parts.

Ensure the insulation plate at the AC terminal block is securely fastened and not Loose.

Ensure all cable connections are tight, Otherwise, overheating of the terminals during equipment operation may cause equipment damage.

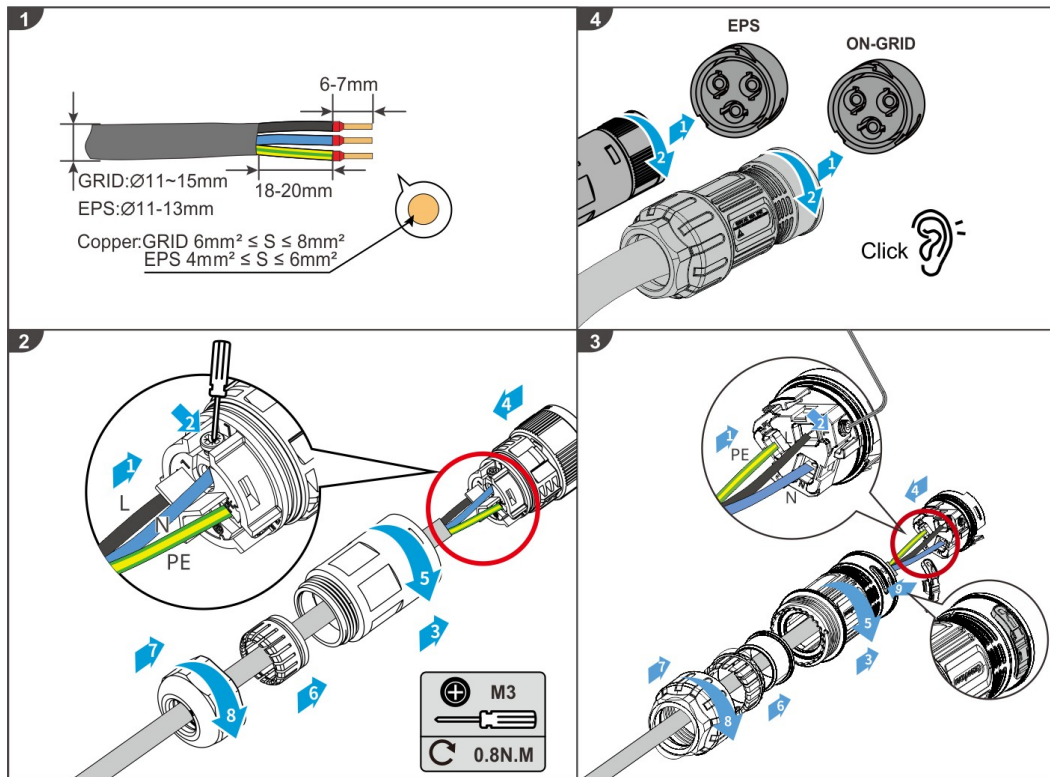
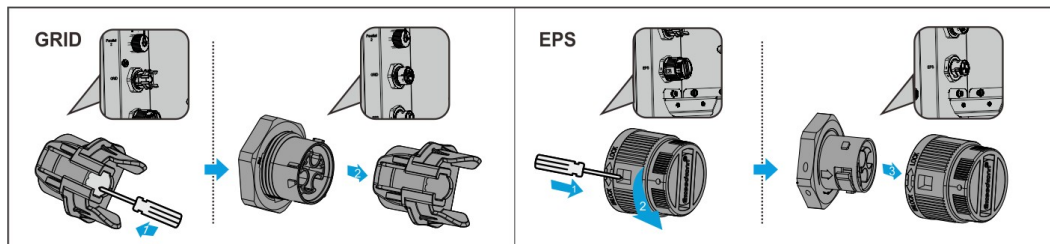

After connecting the power grid side and EPS side connectors, install the side decorative cover and fasten it with screws. When disconnecting the power grid side and EPS side connectors, first remove the side decorative cover with a screwdriver before unlocking the power grid and EPS connectors. Instructions on how to disconnect the Grid and EPS connectors are shown below:

GRID: Tighten the unlock key to the Click, then pull the plug

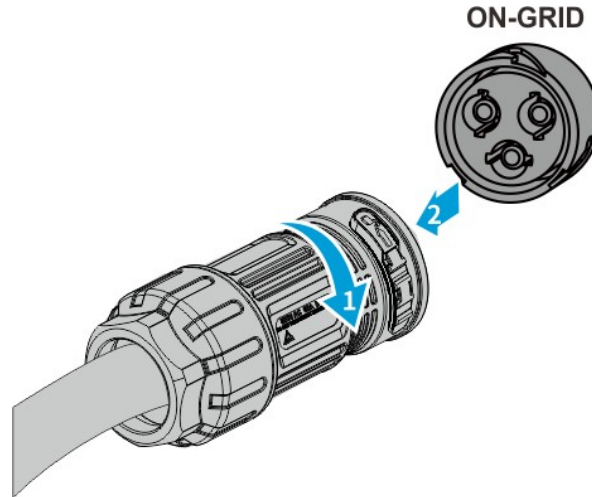

EPS : Use the unlocking tool/Screw Driver to press the buckle to unlock the connector, rotate the connector according to the direction instructed by the marks to pull the backup connector out. And put cover back for safety consideration.

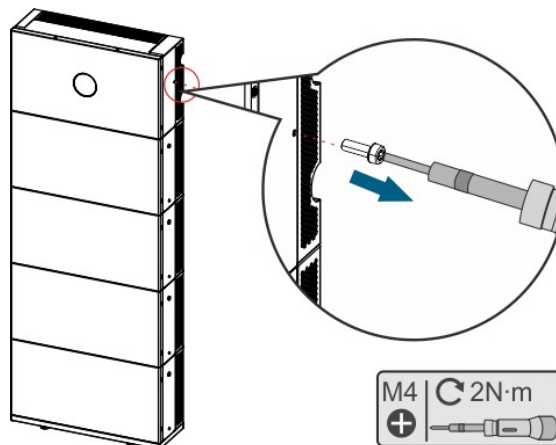
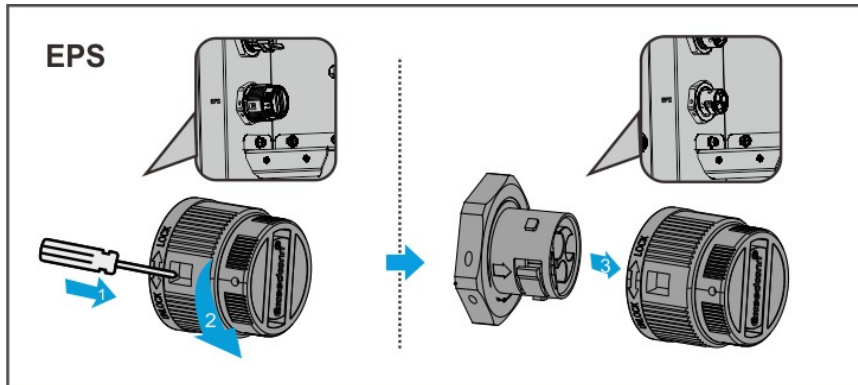

(Optional) connecting the Manual Transfer Switch:

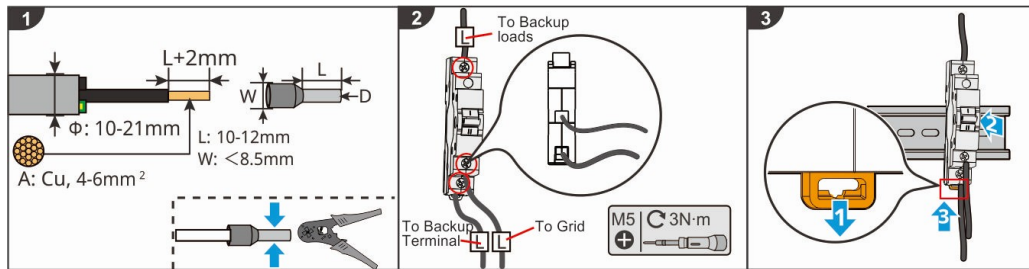
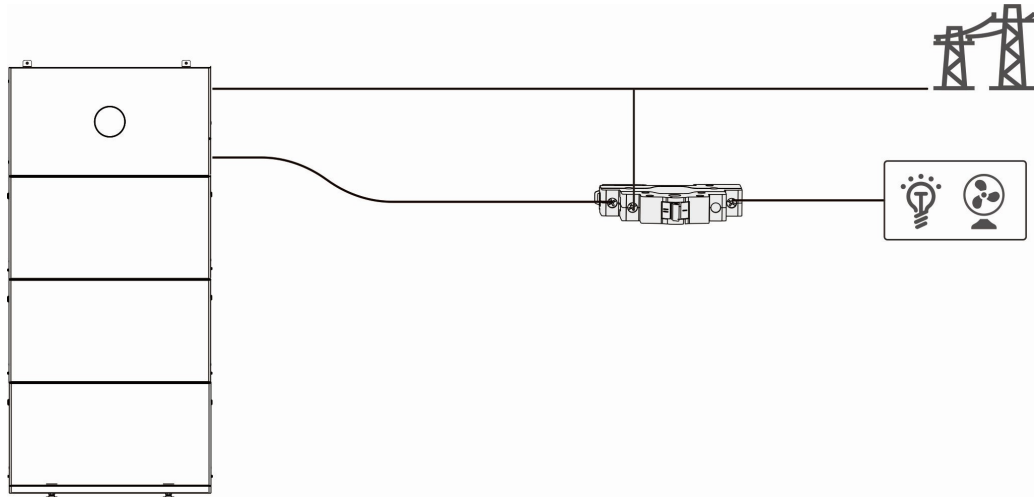

6.6 CT/Meter Connection



If multiple Inverter Parallel Networking units are required, please consult the manufacturer to purchase the meter separately.

Please ensure the CT connection direction is correct and the phase is accurate; otherwise, it may lead to incorrect monitoring data.

Ensure all cable connections are correct, secure, and free from looseness. Improper wiring may cause poor contact or damage to the meter.

The outer diameter of the AC power line must be smaller than the CT aperture to ensure the AC power line can pass through the CT.

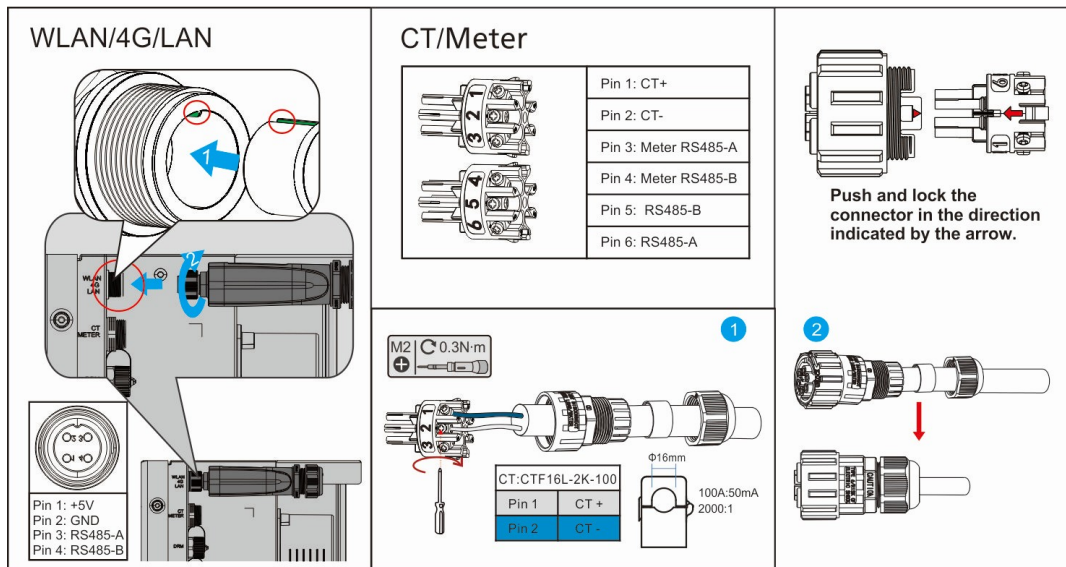

Supports connection to third-party monitoring platforms via the Modbus communication protocol. Users can implement the VPP function by connecting PIN5 and PIN6 in the CT/METER.

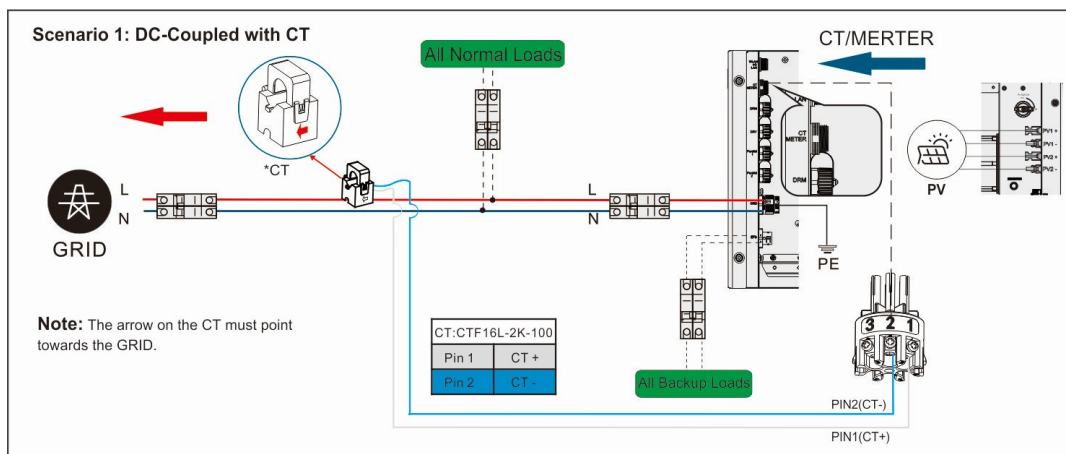

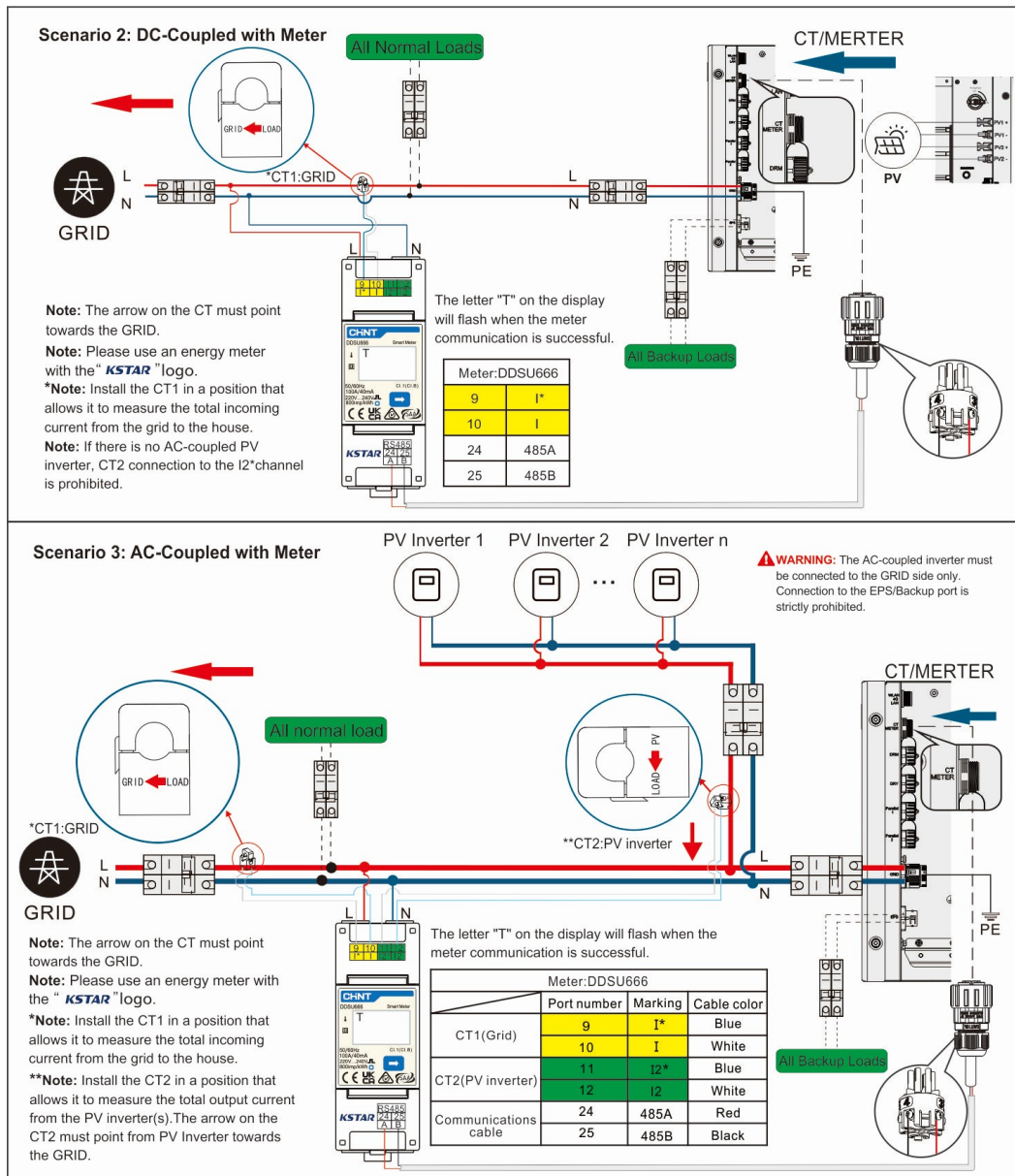

6.7 DRM Connection



For use if required DRM Remote Shutdown function, please ensure the wiring is completed before proceeding. Sync App Enable this function.

If Not connected DRM not operate equipment or Remote Shutdown equipment while Sync App Enable this function, otherwise the Inverter cannot On-Grid operate.

The outer diameter of the AC power line must be smaller than the CT aperture to ensure the AC power line can pass through the CT.

Table-DRM Connector Pin Descriptions

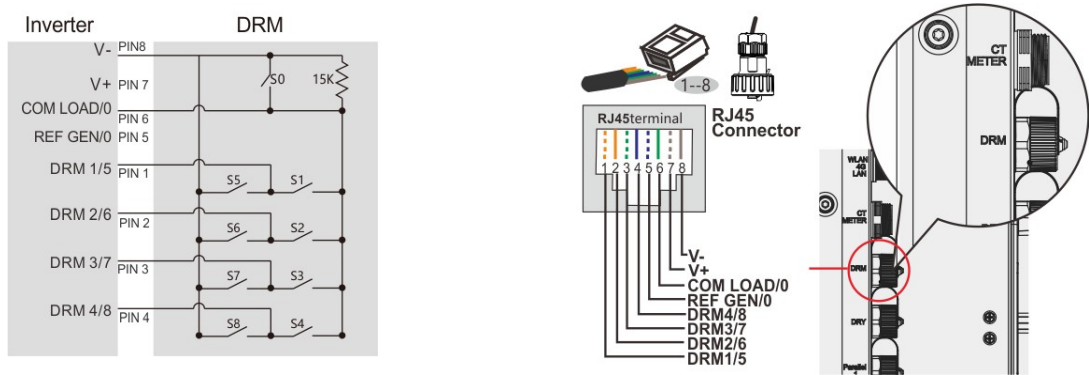

In the “PIN x” columns, “0” means the corresponding relay is closed and “1” means the corresponding relay is opened.

PIN4	PIN3	PIN2	PIN1	PIN6	Active Power	Cos(Q)
1	0	1	1	1	0%	1
1	1	0	1	1	30%	1
1	1	1	0	1	60%	1
1	1	1	1	0	100%	1
1	1	1	1	1	100%	1
0	X	X	X	X	Standby	1

7 System Commissioning

7.1 Pre-power Check

Check the following items before starting the inverter:

.All equipment has been reliably installed.

DC switch and AC circuit breaker are in the "OFF" position.

. The ground cable is properly and reliably connected.

. The AC cable is properly and reliably connected.

The DC cable is properly and reliably connected.

.The communication cable is properly and reliably connected.

*The unused terminals are sealed

The AC circuit breaker is selected in accordance with the requirements of this manual and local standards.

All warning signs & labels are intact and legible.

7.2 Power ON Procedure

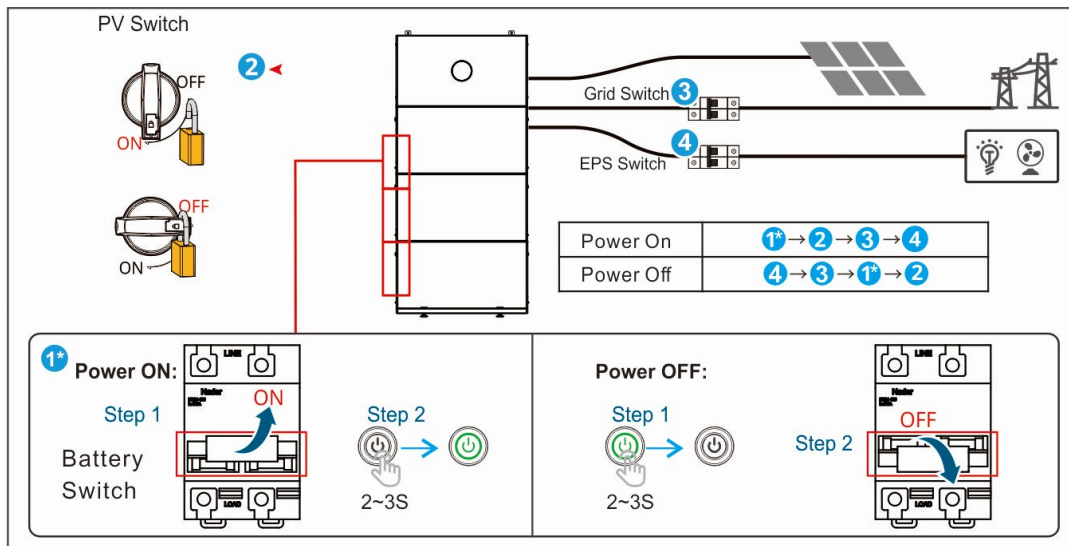

- First, flip the battery breakers of all battery packs upward to the ON position. Then, press and hold the battery button for 2-3 seconds until the battery button shows green and remains constantly lit.
- Rotate the PV switch of the inverter to "ON" position.
- Turn on the AC switch between the inverter and the power grid
- Turn on the EPS breaker

7.3 Install Protective Covers

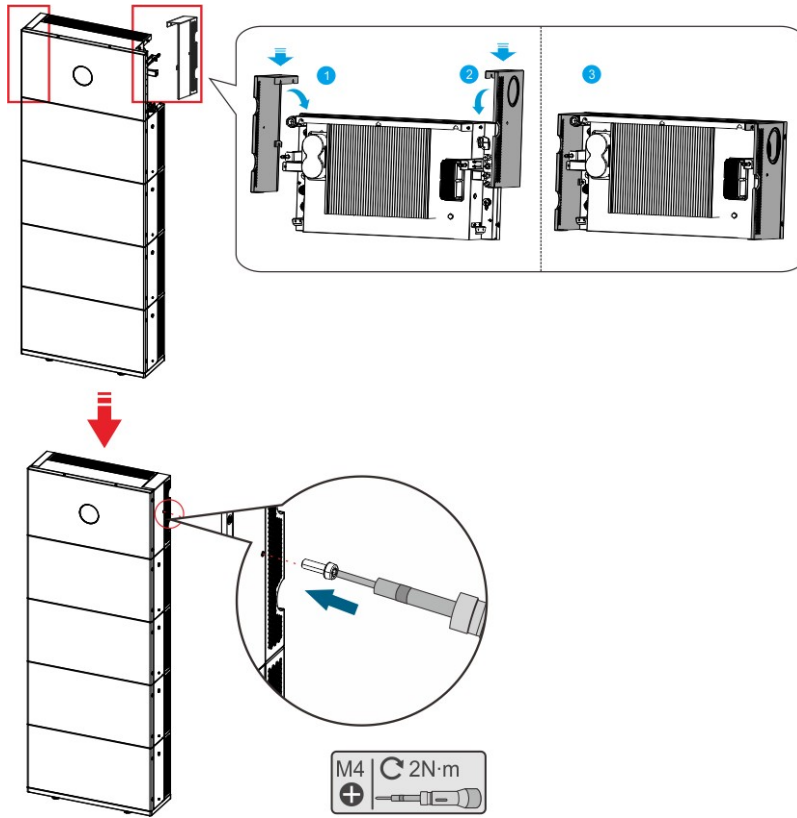

7.4 App Commissioning

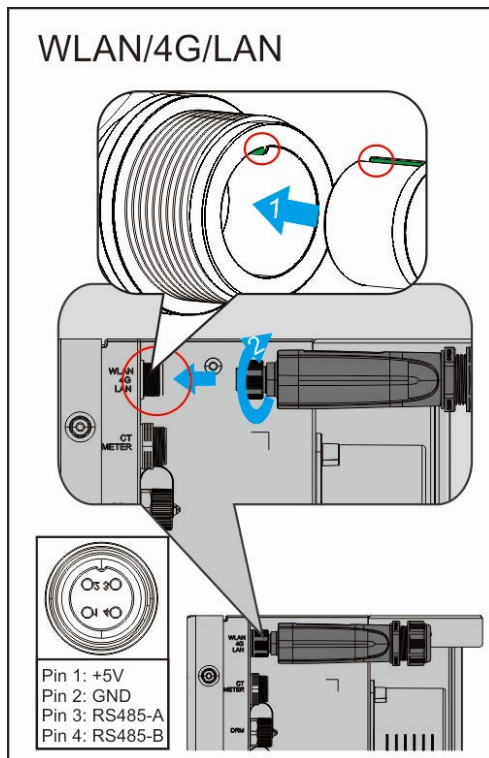

7.5 KSTAR Sync APP

About This Manual

Users

This manual is for end users of KSTAR Sync APP (hereinafter referred to as this APP).

Copyright Notice

Copyright 2025© Shenzhen Kstar Science & Technology Co.,Ltd

Without authorization, no organization or individual may copy part or all of the content of this manual without permission. KSTAR reserves the right to modify this manual at any time without notifying users one by one. If users have objections to this manual, they can contact KSTAR. KSTAR has the final interpretation right.

Contact KSTAR

If you have any questions, please contact KSTAR.

Website: <https://www.kstar.com/>

Email: service_solarinverter@kstar.com

7.6 Download APP

1. Android: Visit Google Play Store, search and download KSTAR Sync.
2. iOS: Visit App Store, search and download KSTAR Sync.
3. QR Code: Scan the QR code below to download KSTAR Sync.



7.7 System Operation

7.7.1 Local Mode

1. Install the Stick Logger and power it on. Turn on Bluetooth on your phone and connect to Wi-Fi. Open the "KSTAR Sync" APP, tap Network Configuration, and proceed to the QR code scanning page as shown in the figure below.

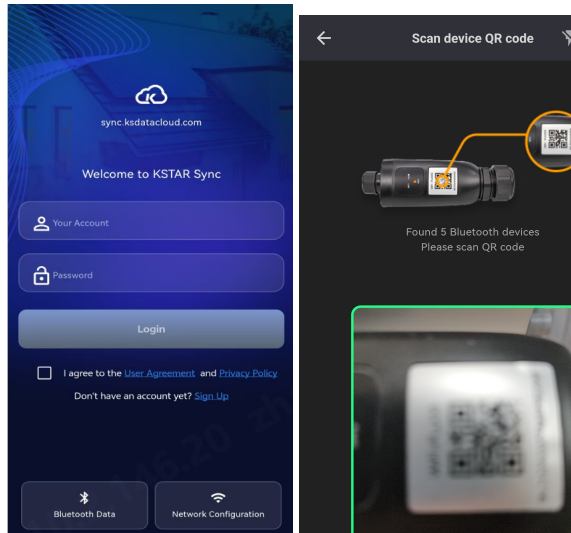

2. **Stick Logger (WiFi):** Scan the QR code on the Stick Logger to access the WIFI configuration page. Enter the current WIFI password, then click "Start Network Configuration". After successful configuration, click OK to exit. Otherwise, reconfigure.

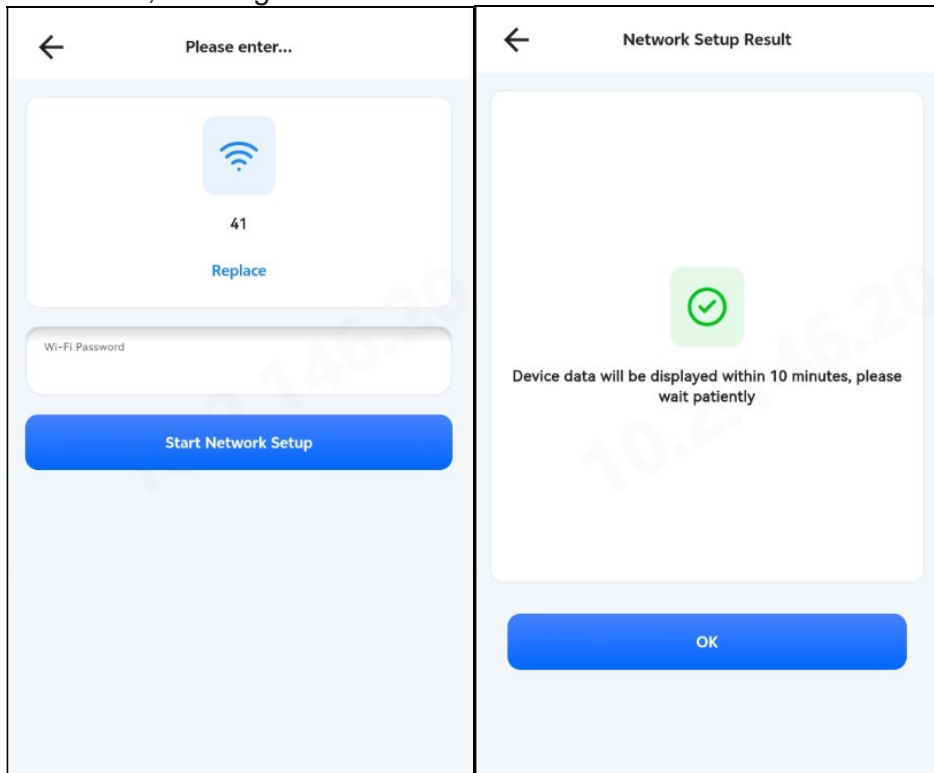

3. Complete configuration. The NET indicator light on the data acquisition stick will then flash rapidly.

7.7.2 Utility Standard

Under this setting, installer will choose the relevant utility standard that applies to your energy storage system by the password access.



Utility Standard are password protected. Please contact your installer or distributor for access.

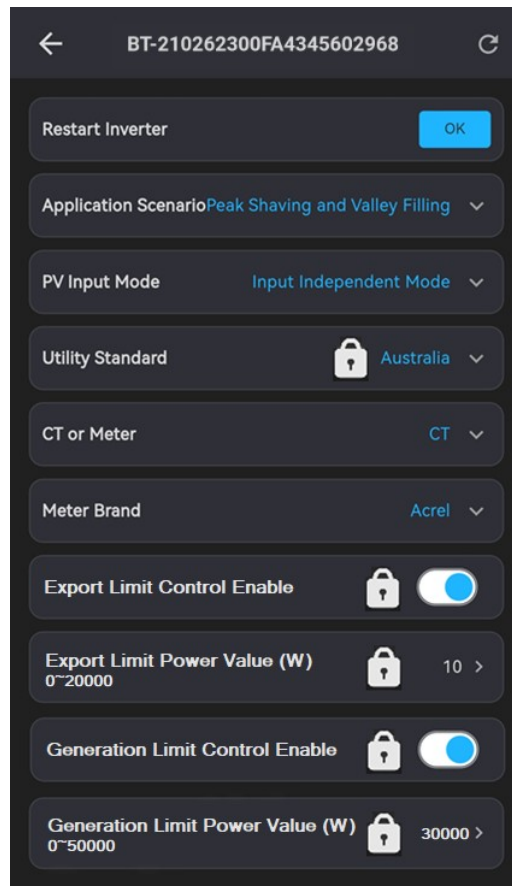

Table 6-1 lists the specifications of different utility standards.

Table 6-1 Grid Specifications

Grid		Output Voltage Range (VAC)	Output Frequency Range (Hz)	Start Delay (s)
1	China	187–252	49.5–50.2	30
2	Germany	184–264	47.5–51.5	60
3 Australia	AUS-A	180–265	47–52	60
	AUS-B	180–265	47–52	60
	AUS-C	180–265	45–55	60
4 Italy	CEI0-21	195–264	49.8–50.2	60

	CEI0-21 ACEA	195–264	49.8–50.2	60
5	Spain	196–253	48–50.5	180
6	U.K.	184–264	47–52	180
7	Hungary	196–253	49–51	300
8	Belgium	184–264	47.5–51.5	60
9	New Zealand	180–260	45–55	60
10	Greece	184–264	49.5–50.5	180
11	France	184–264	47.5–50.4	60
12	Bangkok	198–242	49–51	150
13	Thailand	198–242	47–52	60
14	South Africa	180–260	47.0–52	60
15	50549	184–264	47.5–51.5	60
16	Brazil	184–264	59.5–60.5	60
17	0126	184–264	47.5–51.5	60
18	Ireland	184–264	47–52	180
19	Israel	195.5–253	47.0–51.5	60
20	Poland	195.5–253	49.00–50.05	60
21 Chile	Chile-BT	176.0–242	47.5–51.5	60
	Chile-HD	198.0–242	49–51	300
	Chile-LD	198.0–242	49–51	300
22	Local	150–280	45.0–55	30
23	60Hz	184–264	59.5–60.5	60
24	Denmark	195.5–253.0	47.5–51.5	60
25	Sweden	195.5–253.0	47.5–51.5	60
26	Austria	184–264.5	47.5–51.5	300
27	Czech	195.5-253	47.5-52	60
28	Cyprus	184-253	47-51.5	180
29	Netherlands	184-253	48-51	60
30	Switzerland	184-276	47.5-51.5	60

7.7.3 Grid Setting

When you select the grid standard in Utility Standard, these parameters are set automatically. During operation, when the inverter detects that these settings have been reached or exceeded, the inverter stops generating power.



Changing the setting of Utility Standard is not recommended. Utility Standard are password protected. Please contact your installer or distributor for access.

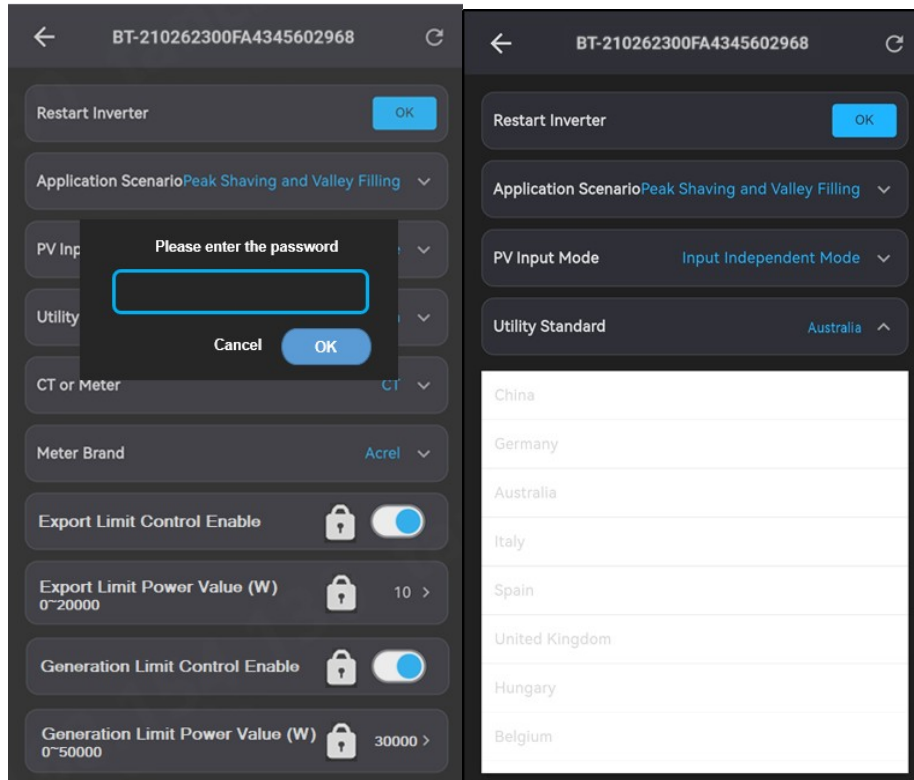

7.7.4 Application Scenario setting

WORK MODE

The E4KT/E5KT/E6KT/E8KT/E10KT/E12KT-D22 supports three working modes: **SELF-CONSUMPTION**, **PEAK SHAVING AND VALLEY FILLING**, and **BATTERY PRIORITY**. For more information, see Application Scenario.

SELF-CONSUMPTION: This is the default working mode. In this mode, the batteries are charged by the PV panel by default. Prioritizes consuming photovoltaic power generation, surplus electricity is stored in battery, when insufficient, battery discharges, maximize green electricity self-use rate.

On the **Charging Control** option, when **Charging Enable** is enabled, you can set the time (up to two each) and the “Charging Power Limit” for charging. Charging will automatically stop when the set time.

PEAK SHAVING AND VALLEY FILLING: Discharges during peak electricity hours to reduce grid demand, charges during load valley periods, smooths electricity curve, reduces capacity electricity fees.

On the **Power Control Enable** option, it's available to select the "Forced Charge" or "Forced Discharge". After enabling power control, you can set the peak power and valley power of the load power.

The operation logic is shown in the figure:

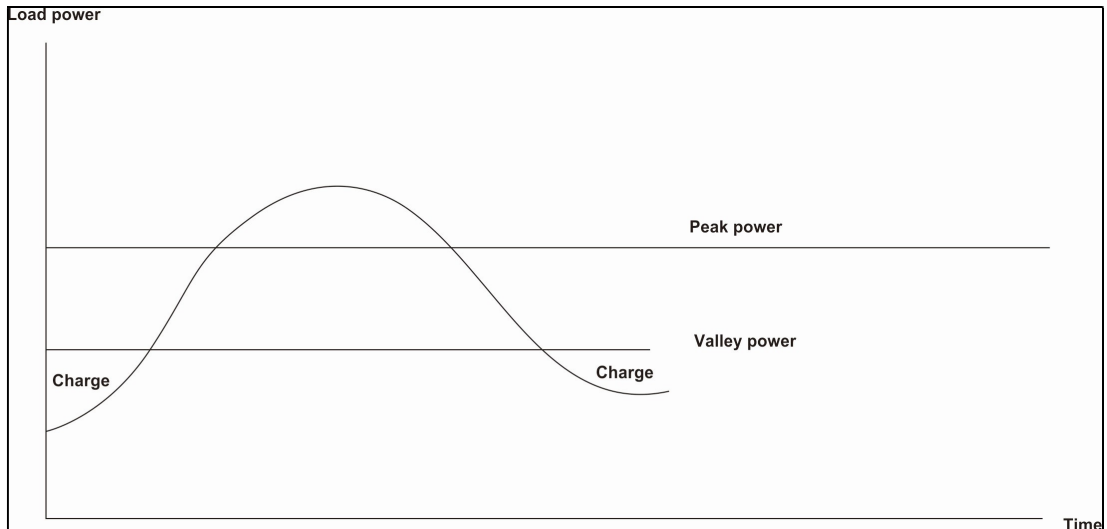

The peak power setting value must be greater than the valley power, otherwise the setting will be invalid.

BAT PRIORITY: Prioritizes supplying load from battery (discharge), photovoltaic electricity is used for charging; if battery is insufficient, then uses power grid.

7.7.5 Export Limit Control and Generation Limit

Export Limit Control feature is available to enable/disable the limitation of power export to grid. Generation Limit Control feature is available to enable/disable the limitation of power generation from the inverter.

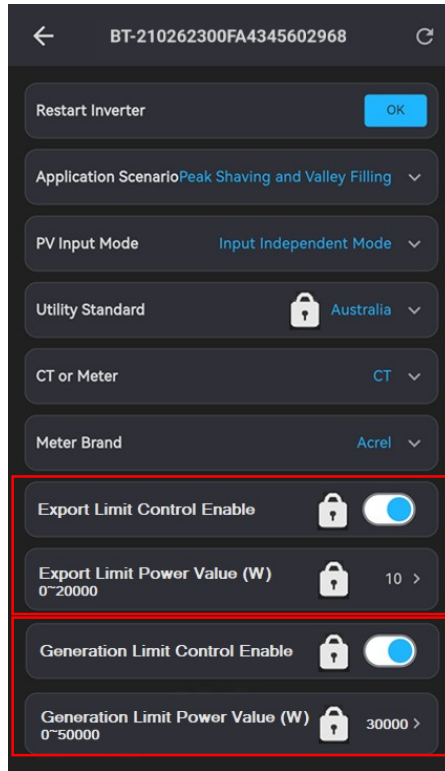

Export Limit Control Configuration are password protected. Please contact your installer or distributor for access.

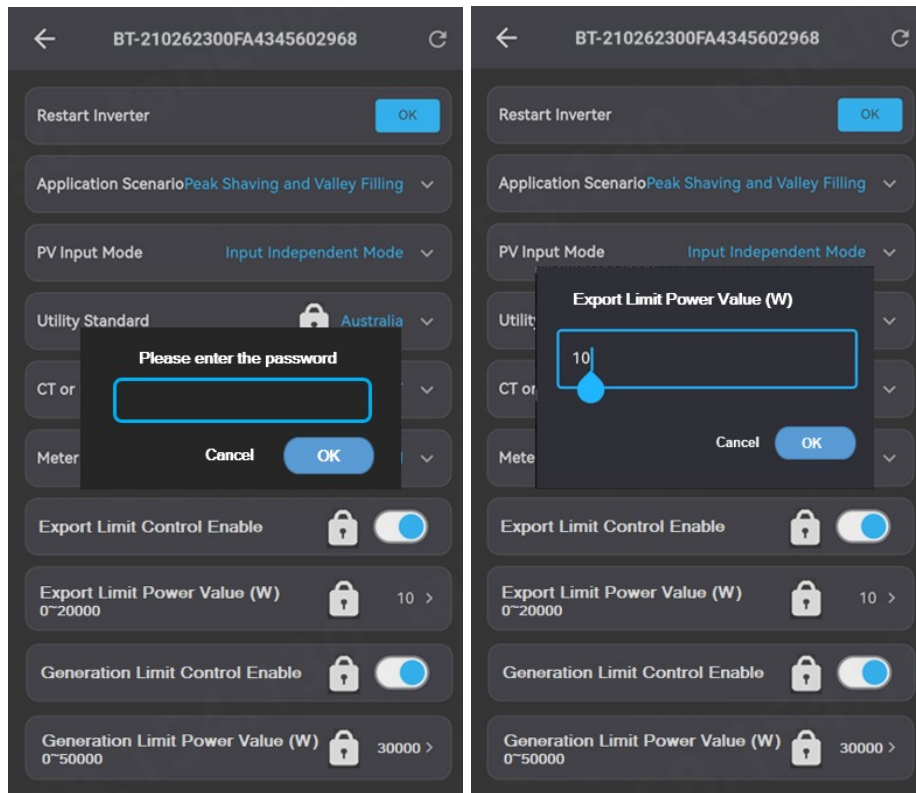

7.7.6 PV Input Mode

There are three modes for PV inputs: independent, parallel and constant voltage. Set the appropriate PV input mode based on the actual connection of the PV strings.

The default setting is INDEPENDENT. If independent mode is selected when the PV strings are actually connected in parallel, it results in an imbalanced distribution of power in the PV strings.

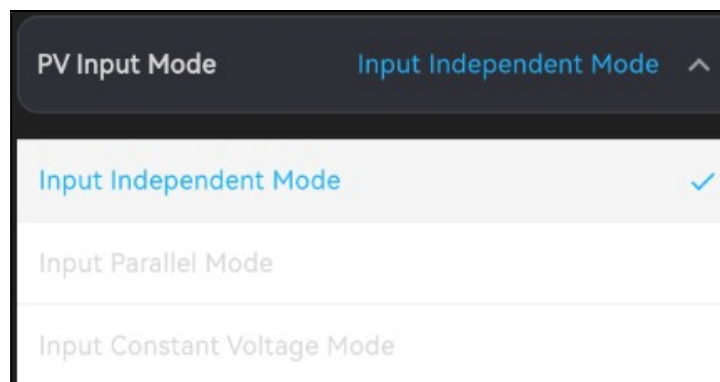

7.7.7 System-setting

Restart Inverter

The command can be issued to restart the inverter.

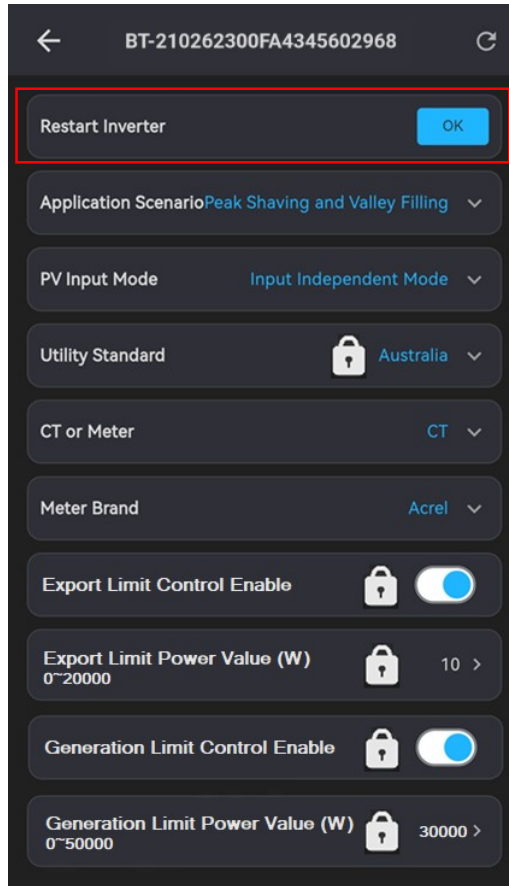

CT OR METER

The E3.68KS/E5KS/E6KS-D22 support connecting external CT or a smart meter for measuring the energy consumption.

By default, CT is selected. If you want to connect a smart meter, five brands are supported currently. The CHINT DDSU666 is recommended.

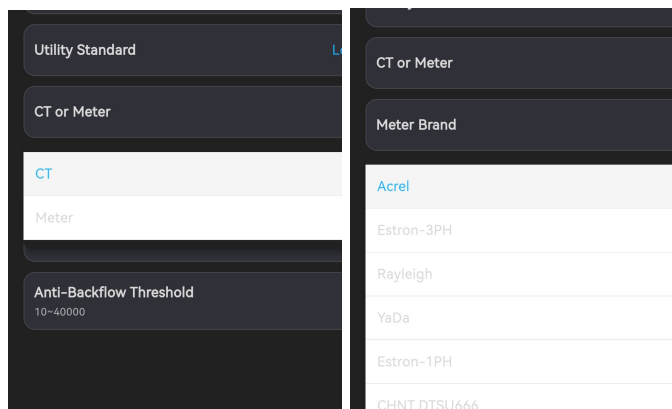

7.7.8 Equipment Basic Information

- **FIRMWARE:** The version of the firmware in ARM and DSP.
- **MODEL SN:** The serial number of the hybrid inverter in use.
- **INV MODEL:** The model of the hybrid inverter in use.
- **Bat Name:** The serial number of the battery in use.
- **System Time:** The date, and time of the system.

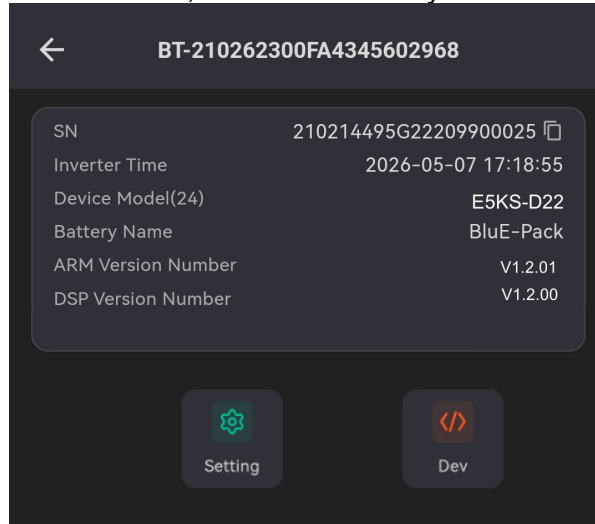

7.7.9 PV Information

In this interface, you can view the voltage, current, and power of the two photovoltaic inputs, PV1 and PV2, of the inverter.

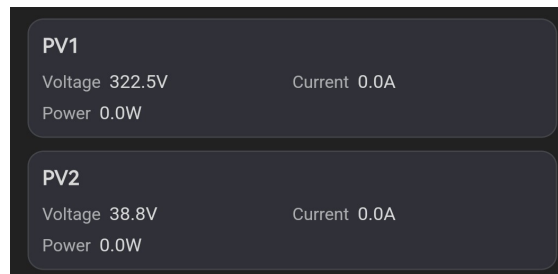

7.7.10 Alert

The fault codes of the inverter in operation can be viewed on this interface.

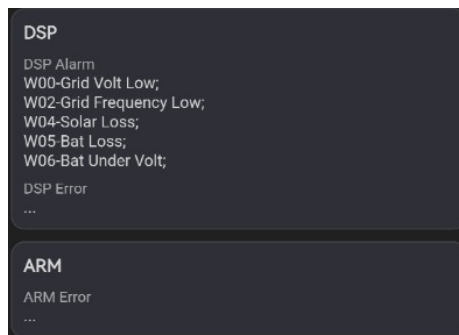

7.7.11 Inverted/Grid Information

In this interface, you can view the inverter's Inverted/Grid voltage, current, frequency, and power status.

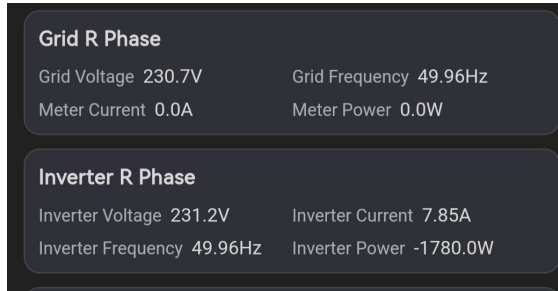

7.7.12 BACK UP Information

The inverter's load-side voltage, current, frequency, and power status can be viewed on this interface.

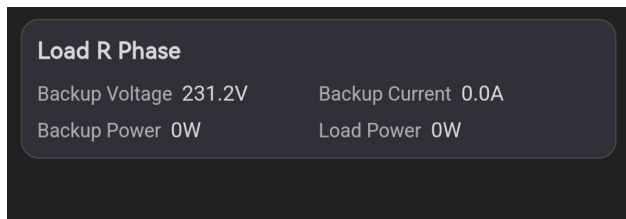

7.7.13 Battery Information

Under this option, you can view the Battery Voltage, Battery Current, Charging and Discharging Power, Remaining Capacity (SOC) of all connected battery packs.

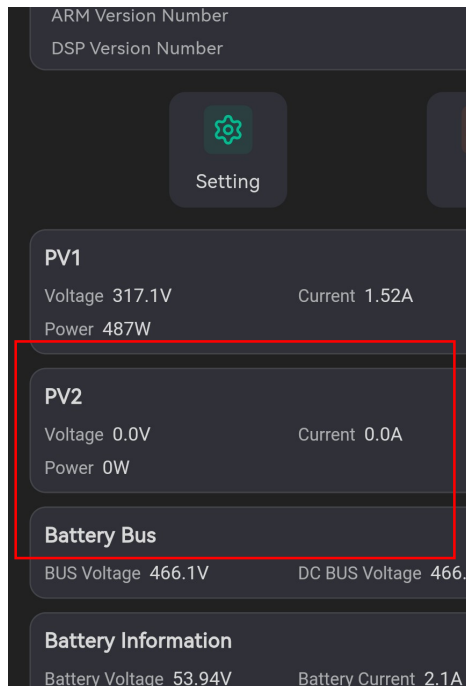

7.7.14 Grid Protection Setting and Power Quality Response Mode

Under Developer Functions Tab, and enter the Grid Settings option, will be able to view the Under/Over Voltage and Under/Over Frequency protection value. There are additional options to enable the Over-voltage/ Under-voltage Derating, Over-frequency/ Under-frequency Derating and relevant threshold value.

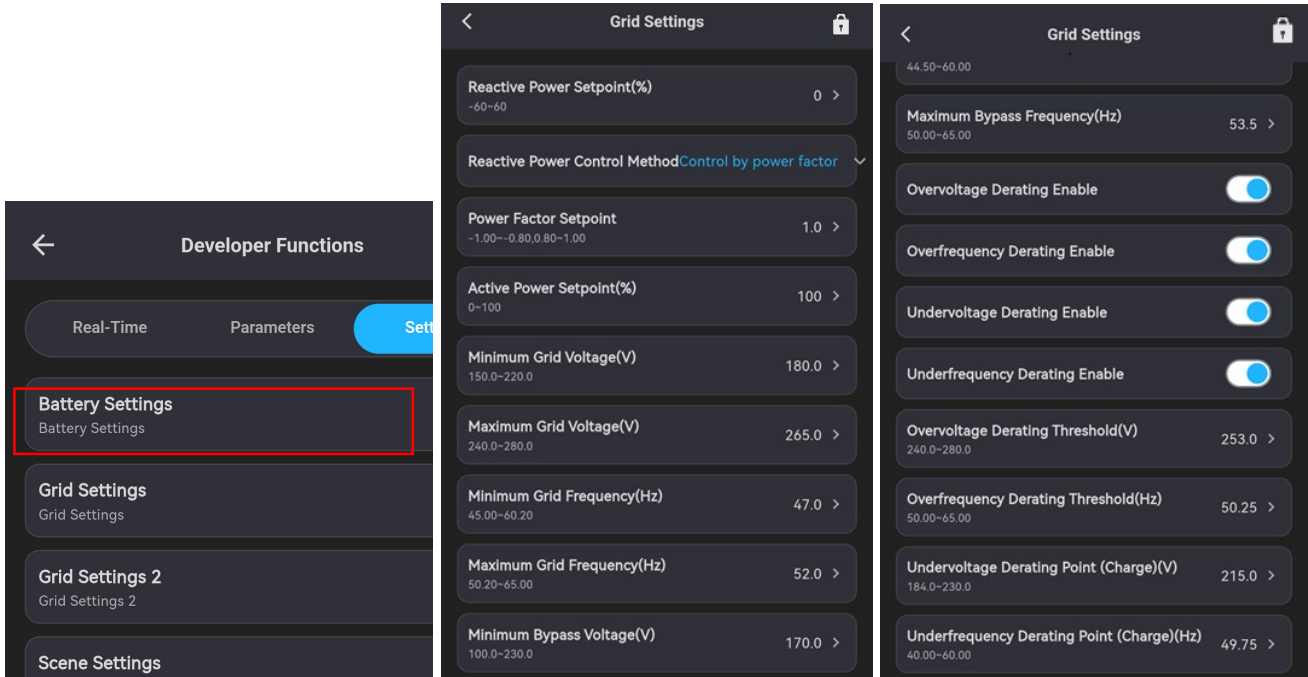

Enter the Advanced Function Setting, will get the options to view multiple Power Quality Response mode, Q(u), P(u), P(f), PF, Q control, Max_Power rate, QP control, etc.

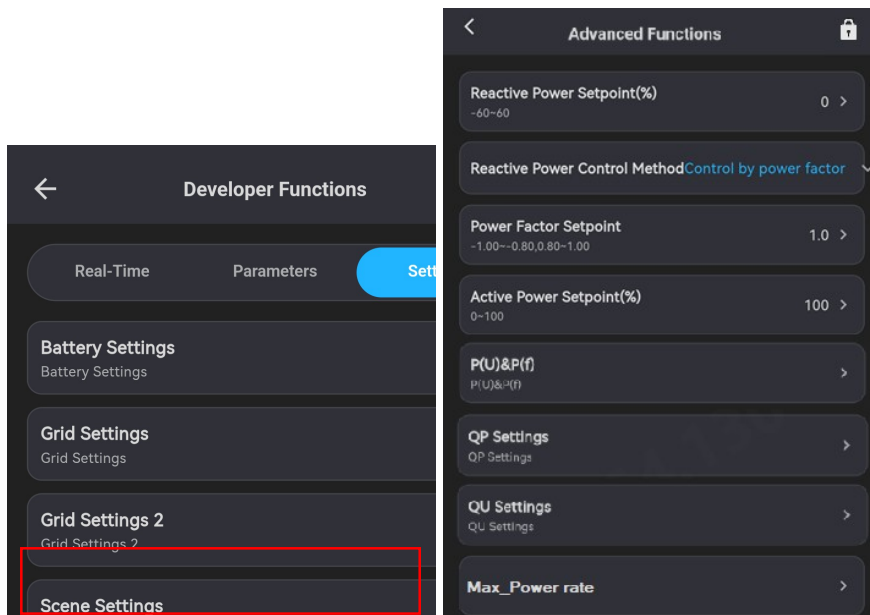



Setting for power quality response are password protected. Please contact your installer or distributor for access.

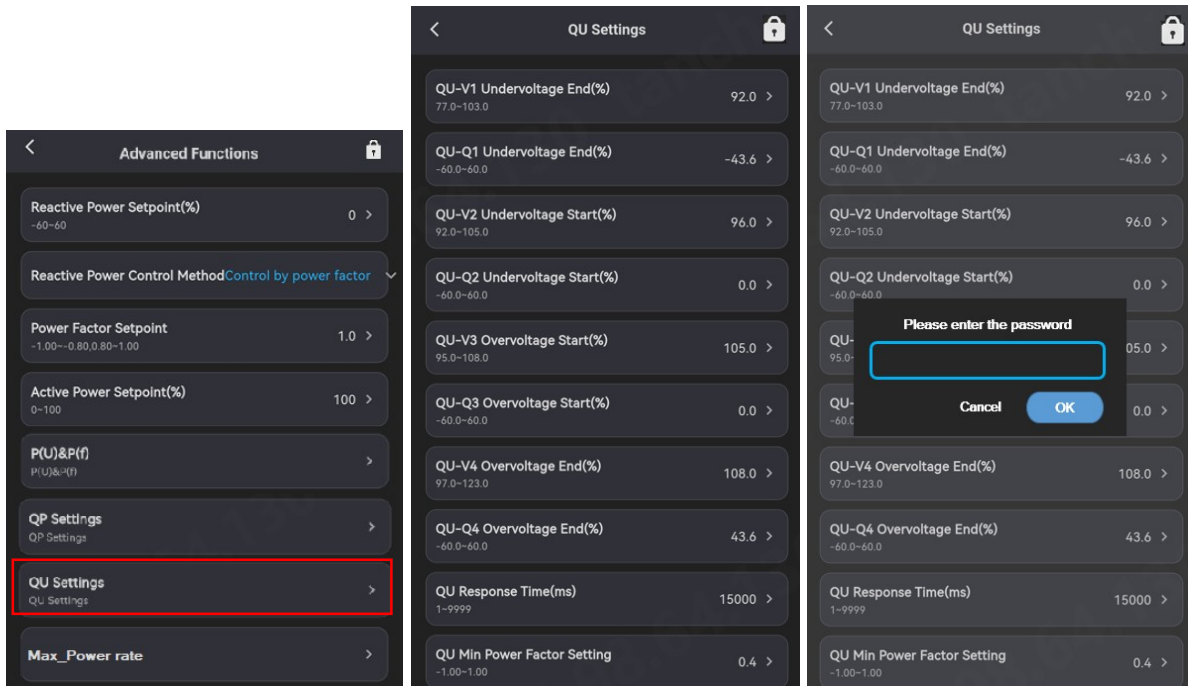

7.7.15 Others Information

- PV Input Mode: Display PV input mode, independent, parallel or constant voltage mode.
- Application Scenario: The system application scenarios of inverters.
- System Status: System status
- Battery BUS Voltage: The real-time value of the Battery bus voltage.

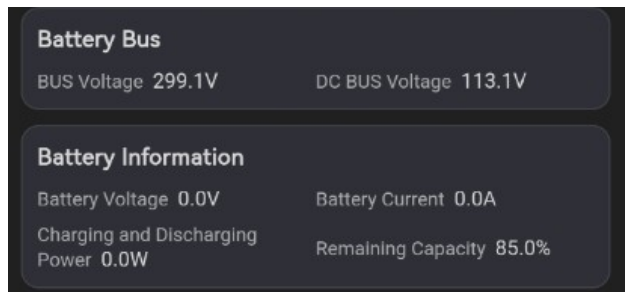

8 Operation & Maintenance

Both users and certified professional personnel must maintain the E3.68KS-D22/E5KS-D22 hybrid inverter to ensure the healthy and safe operation of the system.

In this section, you can find the following:

- The inspection checklist for users of the energy storage system.
- The inspection checklist for professional personnel.
- Error codes, alarm codes, and the possible solutions of the system and the BMS.

8.1 Inspection Checklist for Users

Inspection Activity	Interval
Check for visible damage to any part of the system.	Six months
Check the inverter and battery packs for signs of wear and tear, heat damage, discoloration, and unusual smells.	Six months
Check the warning signs and guidance signs on the inverter and the battery pack for signs of wear and damage, and make sure none have been removed or obscured.	Six months
Check whether any part of the system makes an abnormal noise when the system is running.	Six months
Monitor the temperature of the battery pack and clean the battery pack if necessary.	Six months to a year
Make sure that the ground around the system is clean and tidy.	Six months to a year
Check the maintenance access to make sure that it is clear and unobstructed.	Six months to a year
When the system is running, check the voltage, temperature, and other parameters of the battery packs.	Six months
When the system is running, check the parameters of the inverters.	Six months
Check the battery packs for ineffectiveness or damage.	Six months

8.2 Inspection Checklist for Professional Personnel

WARNING

- The equipment must be opened only by professional personnel that have been certified by KSTAR New Energy.
- During inspection and maintenance, wear protective personalequipment, including insulated gloves, protective shoes, and anti-noise earplugs.
- Follow local and international safety standards, regulations, and specifications to do the maintenance.
- Contact KSTAR New Energy promptly if you encounter anything not covered in this manual.

CAUTION

Before maintenance, disconnect all the electrical connections. Wait at least five minutes after disconnection, so that the residual voltage of the capacitors falls to a safe voltage. Use a multi-meter to make sure that the equipment is completely discharged.

Inspection Activities	Interval
Check electrical connections for looseness.	Six months to a year
Check cables for deterioration or damage.	Six months to a year
Check cable terminal screws for looseness.	Six months to a year
Check cable terminals for signs of overheating.	Six months to a year
Check the ground connection.	Six months to a year
Check whether the cable tie is attached to the cable.	Six months to a year
Check the EMS, KSTAR SYNC app, and other related equipment for failure or damage.	Six months to a year

8.3 Troubleshooting

When you see the red alarm light on the inverter, you can find possible solutions in this section. If the problem persists after trying these solutions, please contact KSTAR New Energy or an authorized distributor.

When a problem is successfully solved, after a period of time, the red LED alarm light turns off., but you can always view it in the error records. For more information, see Viewing INQUIRE.

8.3.1 Error Codes of the System

Code	Description	Possible Solutions
F00	Soft Time Out: Soft-start timeout.	Restart the inverter and wait until it runs correctly. If the code is still shown, contact Customer Service.
F01	INV Volt Short: The inverter output is shorted.	<ol style="list-style-type: none"> 1. Disconnect all power sources and shut down the inverters and the battery packs. 2. Disconnect the load. 3. Power on and restart all the inverters and the battery packs. 4. If no error is reported, it means the load is shorted. Check the load. If the code is still shown, contact Customer Service.
F02	GFCI Sensor Fault: A failure occurs to the Ground Fault Circuit Interrupter (GFCI) sensor.	<ol style="list-style-type: none"> 1. Disconnect all power sources. 2. Restart the inverter and wait until it runs correctly. If the code is still shown, contact Customer Service.
F04	Bus Volt Low: The bus voltage is low.	<ol style="list-style-type: none"> 1. Check the settings of the input mode. 2. Restart the inverter and wait until it runs correctly.
F05	Bus Volt High: The bus voltage is high.	If the code is still shown, contact Customer Service.
F06	Bus Short Circuit: The bus is shorted.	Restart the inverter and wait until it runs correctly. If the code is still shown, contact Customer Service.
F07	PV ISO Under Fault: The insulation resistance of a PV panel is low.	<ol style="list-style-type: none"> 1. Check the ground connection. 2. Check the ground resistance of PV+ and PV-: <ul style="list-style-type: none"> ▪ If the resistance is smaller than 2 MΩ, check the PV string for ground fault or poor ground insulation. If necessary, contact Customer Service. ▪ If the resistance is greater than 2 MΩ and the error code is still shown, contact Customer Service.

F08	PV Input Short Circuit: The PV input is shorted.	<ol style="list-style-type: none"> 1. Check the settings of the input mode. 2. Disconnect the PV input. 3. Restart the inverter and wait until it runs correctly. <p>If the code is still shown, contact Customer Service.</p>
F09	Bypass Relay Fault: A failure occurred to the bypass relay.	<ol style="list-style-type: none"> 1. Disconnect the PV input. 2. Restart the inverter and wait until it runs correctly.
F19	EPS Relay Fault: A failure occurred to the EPS relay.	<p>If the code is still shown, contact Customer Service.</p>
F10	INV Curr Over: The output current on the inverter exceeds the threshold.	<ol style="list-style-type: none"> 1. Wait five minutes for the inverter to restart automatically. 2. Check the EPS loads. If the load exceeds the rated output power of the inverter, disconnect some load. <p>If the code is still shown, contact Customer Service.</p>
F11	INV DC Over: The DC component of the output current of the inverter is too high.	<p>Restart the inverter and wait until it runs correctly.</p> <p>If the code is still shown, contact Customer Service.</p>
F12	Ambient Over Temp: The ambient temperature is too high.	<ol style="list-style-type: none"> 1. Restart the inverter. 2. Let the inverter cool for a few minutes and then restart it.
F13	Sink Over Temp: The temperature of the heat sink is too high.	<ol style="list-style-type: none"> 3. Observe whether the inverter can run correctly. 4. Make sure that the ambient temperature is in the range of -25°C to 60°C. <p>If the code is still shown, contact Customer Service.</p>
F15	DisChg Curr Over: The battery is discharged with over current.	<ol style="list-style-type: none"> 1. Wait five minutes for the inverter to restart automatically. 2. Check the EPS loads. If the load exceeds the rated output power of the inverter, disconnect some load. <p>If the code is still shown, contact Customer Service.</p>

Code	Description	Possible Solutions
F16	Chg Curr Over: The battery is charging with over current.	Check the battery wiring port for short circuits. Restart the inverter and the battery packs. If the code is still shown, contact Customer Service.
F17	Current Sensor Fault: A failure occurred to the current sensor.	Restart the inverter and wait until it runs correctly. If the code is still shown, contact Customer Service.
F18	INV Abnormal: Abnormal output voltage or output frequency of the inverter.	Contact Customer Service.
F20	Always Over Load: The EPS load always exceeds the rated output power of the system.	Check the EPS loads. If the load is lower than the rated output power of the inverter and the error is still shown, contact Customer Service.
F22	Parallel Communicate Fault: A failure occurred to the communication between the inverters in a parallel system.	1. Check the parallel cable for connection. 2. Check the inverter address settings. In a parallel system, the address of the primary inverter must be set to 1, and the addresses of the other inverters must be set to 2, 3, or 4. If the code is still shown, contact Customer Service.
F23	Parallel Grid Abnormal: In a parallel system, some connections are incorrect.	1. Check the wiring at the grid end and make sure the wiring is correct. 2. Restart the inverter and wait until it runs correctly. If the code is still shown, contact Customer Service.
F24	EPS Air Switch Abnormal: An error occurred to activation of the air switch on the EPS load end.	1. Turn off all the switches on the EPS load end. 2. If the code is still shown, contact Customer Service.
F25	Parallel Power Imbalance: Power imbalance occurs to the parallel system.	1. Turn off all the switches on the EPS load end. 2. Restart the inverter and wait until it runs correctly.
F26	Parallel Inverter Grid Phase Sequence Abnormal	1. Make sure that the phase sequence at the grid end of the inverter is consistent. 2. If the code is still shown, contact Customer Service.

F32	DSP ARM SCI Fault: A failure occurs to the communication between DSP and ARM.	Restart the inverter and wait until it runs correctly. If the code is still shown, contact Customer Service.
------------	--	---

8.3.2 Alarm Codes of the System

Code	Description	Possible Solutions
W00	Grid Volt Low	Check the local voltage and frequency for their compliance with the inverter specifications: <ul style="list-style-type: none"> • If the voltage and frequency are within the acceptable range, wait two minutes for the inverter to run correctly. If recovery is not possible or the fault repeats, contact Customer Service. • If the voltage and frequency are beyond the range or are unstable, contact the local power company.
W01	Grid Volt High	
W02	Grid Frequency Low	
W03	Grid Frequency High	
W04	Solar Loss: No PV solar panels are connected to the system, or the input voltage from the PV solar panels is too low.	1. Check the PV connection. 2. Check the PV availability. If the connections are correct and the alarm code is still shown, contact Customer Service.
W05	Bat Loss: No battery packs are connected to the system, or the battery voltage is too low.	1. Check the battery connection. 2. Check the battery wiring port for short circuits. If the connections are correct and the alarm code is still shown, contact Customer Service.
W06	Bat Under Volt: Under voltage has occurred in the battery.	Check the battery packs for their availability. If the battery voltage is lower than the lowest battery terminal input voltage acceptable to the inverter, charge the battery until it reaches the acceptable battery input voltage of the inverter. If the code is still shown, contact Customer Service.
W07	Bat Volt Low: The battery voltage is too low.	

Code	Description	Possible Solutions
W08	Bat Volt High: The battery voltage is higher than 57.5 V and the battery has shut down because of the high voltage.	<ol style="list-style-type: none"> 1. Check the battery for its compliance with its pre-settings. 2. If the battery complies with the pre- setting, restart it. <p>If the code is still shown, contact Customer Service.</p>
W09	Over Load: An overload has occurred because the connected load exceeds the rated power of the inverter.	<ol style="list-style-type: none"> 1. Wait five minute for the inverter to restart. 2. If the EPS loads are higher than the rated output power of the inverter, disconnect some load.
W10	GFCI Over: High current leakage has occurred.	<ol style="list-style-type: none"> 1. Check the PV string for direct or indirect grounding. If such grounding is discovered, correct it. 2. Check the peripherals of the inverter for current leakage. If current leakage is discovered, address it. <p>If the code is still shown, contact Customer Service.</p>
W12	Fan Fault: The fan has malfunctioned.	<p>Restart the inverter and wait until it runs correctly.</p> <p>If the code is still shown, contact Customer Service.</p>
W13	BAT Power Down: The battery has shut down because the SOC is low.	<p>Check the SOC. Make sure that the SOC is not lower than the difference between 100% and the set DOD. If it is lower than the difference, charge the battery.</p>
W14 W15 W16 W17 W18 W21 W22	BMS alarms.	<p>For more information, see BMS ALARM Warnings.</p>
W19	BMS Volt Imbalance: A voltage imbalance has occurred to the battery of the BMS.	<p>Contact Customer Service.</p>
W20	BMS Communicate Fault: The communication between the BMS and the inverter has failed.	<p>Make sure that the COM cable between the inverter and the battery pack is in good condition and is connected correctly.</p>
W23 W24	BMS protection warning.	<p>For more information, see BMS PROTECTION</p>

Code	Description	Possible Solutions
		Warnings.
W25	BMS Updating: The BMS is updating.	You can ignore this alarm. No action is required.
W26	BMS Program Version Err: The version of the BMS program is incorrect.	Contact Customer Service.
W27	BMS Program Update Fail: The BMS program has failed to update.	Check the network and try to update the program again.
W29	Grid Volt Lock Fail: The inverter has failed to synchronize with the grid.	Restart the inverter and wait until it runs correctly. If the code is still shown, contact Customer Service.
W30	PV Off: The PV string has requested a shutdown.	Restart the inverter and wait until it runs correctly. If the code is still shown, contact Customer Service.
W31	System Reset: The system is reset.	Restart the inverter and wait until it runs correctly. If the code is still shown, contact Customer Service.

8.3.3 BMS Error codes and troubleshooting

Code	Description	Possible Solutions
BIT0	Battery cell overvoltage alarm	The warning unit overcharging voltage is 3650mV, where the inverter should stop charging and the BMS should not turn off the charging MOS.
BIT1	Battery cell under-voltage alarm	The warning unit over discharging voltage is 2800mV, where the inverter should stop discharging and the BMS should not turn off the discharging MOS.
BIT2	Battery PACK overvoltage alarm	The warning overall overcharging voltage is 57.6V, where the inverter should stop charging and the BMS should not turn off the charging MOS.
BIT3	Battery PACK under-voltage alarm	The warning overall over discharging voltage is 44.8V, where the inverter should stop discharging and the BMS should not turn off the discharging MOS.
BIT4	Charging overcurrent alarm	The warning charging overcurrent is 100A, where the inverter should stop

		charging and the BMS should not turn off the charging MOS.
BIT5	Discharging the overcurrent alarm	The warning current of discharging overcurrent 1 is 100A where the inverter should stop discharging and the BMS should not turn off the discharging MOS. This alarm will automatically stop after 1min or when the charging current is greater than 1A.
BIT8	Charging high temperature alarm (cell temperature)	The protective limit of charging high temperature is 57°C where the BMS should forcibly turn off the charging MOS.
BIT9	Discharging high temperature alarm (cell temperature)	The warning discharging high temperature is 55°C, where the inverter should stop discharging and the BMS should not turn off the discharging MOS.
BIT10	Charging low temperature alarm (cell temperature)	The warning charging low temperature is 2°C, where the inverter should stop charging and the BMS should not turn off the charging MOS.
BIT11	Discharging low temperature alarm (cell temperature)	The warning discharging low temperature is -18°C, where the inverter should stop discharging and the BMS should not turn off the discharging MOS.
BIT12	High ambient temperature alarm	The warning high ambient temperature is 65°C, where the inverter should stop charging and discharging and the BMS should forcibly turn off the charging and discharging MOS.
BIT13	Low ambient temperature alarm	The warning low ambient temperature is -15°C, where the inverter should stop charging and the BMS should forcibly turn off the charging MOS.
BIT14	MOSFET high temperature alarm	The warning MOS over-temperature is 90°C, where the inverter should stop charging and discharging and the BMS should not turn off the charging and discharging MOS.
BIT15	Low SOC alarm	The warning low battery SOC is less than 5%, where the inverter should stop discharging and the BMS should not turn off the charging and discharging MOS and should not alarm during charging.

8.3.4 BMS Protection codes and description

Code	Description	Possible Solutions
BIT0	Battery cell overvoltage protection	The unit overcharging protection voltage is 3700mV, where the inverter should stop charging and the BMS should forcibly turn off the charging MOS.
BIT1	Battery cell under-voltage protection	The unit over discharge protection voltage is 2500mV, where the inverter should stop discharging and the BMS should forcibly turn off the discharging MOS. After 30 seconds of over discharge protection, if the battery still cannot be restored, it will enter a low power consumption mode.
BIT2	Battery PACK overvoltage protection	The overall overcharge protection voltage is 59V, where the inverter should stop charging and the BMS should turn off the charging MOS.
BIT3	Battery PACK under-voltage protection	The overall over discharge protection voltage is 40V, where the inverter should stop discharging and the BMS should forcibly turn off the discharging MOS. After 30 seconds of over discharge protection, if the battery still cannot be restored, it will enter a low power consumption mode.
BIT4	Charging overcurrent protection	The protective limit of charging overcurrent is 120A, where the BMS should forcibly turn off the charging MOS. This state will be locked and not be exited automatically if it occurs continuously for 10 times.
BIT5	Discharging overcurrent protection	The protective limit of discharging overcurrent 1 is 130A and the protective limit of discharging overcurrent 2 is 200A with a delay of 100ms, where the BMS should forcibly turn off the discharging MOS. This state will be locked and not be exited automatically if it occurs continuously for 10 times.
BIT6	Short circuit current protection	The short circuit protection current is no less than 350A with a delay of 300us, where the BMS should forcibly turn off the discharging MOS.
BIT7	Charging overvoltage protection	The overall overcharge protection voltage is 59V, where the inverter should stop charging and the BMS

		should turn off the charging MOS.
BIT8	Charging high temperature protection (cell temperature)	The protective limit of charging high temperature is 57°C, where the BMS should forcibly turn off the charging MOS.
BIT9	Discharging high temperature protection (cell temperature)	The protective limit of discharging high temperature is 57°C, where the BMS should forcibly turn off the discharging MOS.
BIT10	Charging low temperature protection (cell temperature)	The protective limit of charging low temperature is 0°C, where the BMS should forcibly turn off the charging MOS.
BIT11	Discharging low temperature protection (cell temperature)	The protective limit of discharging low temperature is -20°C, where the BMS should forcibly turn off the discharging MOS.
BIT12	MOSFET high temperature protection	The protective limit of MOS over-temperature is 110°C, where the BMS should forcibly turn off the charging and discharging MOS.
BIT13	High ambient temperature protection	The protective limit of high ambient temperature is 70°C, where the BMS should forcibly turn off the charging and discharging MOS.
BIT14	Low ambient temperature protection	The protective limit of low ambient temperature is -25°C, where the BMS should forcibly turn off the charging and discharging MOS.
BIT15	Heating function fault	Reset the battery PACK; If the fault is not clear, contact the service engineer.

8.3.5 BMS Fault codes and description

Code	Description	Possible Solutions
BIT0	Charging MOSFET malfunction	Restart the battery PACK, if the fault still exists, contact the manufacturer and lock it until the technical personnel resolve the problem.
BIT1	Discharging MOSFET malfunction	Restart the battery PACK, if the fault still exists, contact the manufacturer and lock it until the technical personnel resolve the problem.
BIT2	Temperature sensor malfunction	Restart the battery PACK, if the fault still exists, contact the manufacturer and lock it until the technical personnel resolve the problem.
BIT3	Cell voltage sampling fault	Reset the battery PACK; If the fault is not clear, contact the service engineer.
BIT4	Battery cell malfunction	Restart the battery PACK, if the fault still

		exists, contact the manufacturer and lock it until the technical personnel resolve the problem.
BIT5	Front-end sampling communication failure	Restart the battery PACK, if the fault still exists, contact the manufacturer and lock it until the technical personnel resolve the problem.
BIT6	Heating control MOSFET fault	Reset the battery PACK; If the fault is not clear, contact the service engineer.
BIT14	Reverse DC connection	Check whether or not the wiring between the battery PACK and the positive and negative wires of the inverter battery is proper.

9 Technical Data

9.1 Hybrid Inverter

Dimension (W × H × D, mm)	725 × 390 × 245
Net Weight (kg)	25 (31kg with base)
Operating Temperature	-25°C to +60°C, Derated over 45°C
Operating Relative Humidity	0–95% (No condensation)
Operating Altitude	≤ 4000 m
Protective Class	Class I
Overvoltage Category	II (DC side), III (AC side)
Topology	Non-isolated (Solar) Isolated (battery)
Cooling	Natural Convection
Display	LED/APP
Communication Interface	RS485, CAN2.0, Wi-Fi, and 4G
Ingress Protection	IP66
Max. Conversion Efficiency (From Battery)	94.8%
Max. Conversion Efficiency (From PV)	97.2 %
Euro Efficiency	95.9% (3.68K) /96.4% (5K) /96.5% (6K)
MPPT Efficiency	99 %
Protection Function	<ul style="list-style-type: none"> • Short Circuit Protection • AC Leakage Fault Protection • Grounding Fault Protection • Anti-islanding Protection • Overload Protection • Surge Protection
Grid Regulation	<ul style="list-style-type: none"> • EN50549-10 • VDE-AR-N4105 • VDE0126-1-1 <p>More grid regulation certifications are to be made available. Please contact KSTAR New Energy for the latest information.</p>
Safety Regulation	<ul style="list-style-type: none"> • IEC/EN 62109-1&2 • IEC62040-1 • IEC62619

EMC	<ul style="list-style-type: none"> • EN61000-6-1 • EN61000-6-2 • EN61000-6-3 • EN61000-6-4 • EN61000-3-2 • EN61000-3-3 • EN61000-3-11 • EN61000-3-12
------------	--

9.2 Battery Terminal Input /Output

	E3.68KS-D22	E5KS-D22
Battery Type	LFP	
Voltage Range	42–58 VDC	
Rated Voltage	48 VDC	
Maximum Charge/Discharge Current	80 ADC/80 ADC	120 ADC/120 ADC
Maximum Charge/Discharge Power	3600 W/3900 W	5,000 W/5,400 W
Maximum Short Circuit Current Rating	300A	

9.3 PV Input

	E3.68KS-D22	E5KS-D22
Vmax. PV	500 VDC	
Rated Voltage	360 VDC	
PV Start Voltage	120 VDC	
MPPT Voltage Range	120–480 VDC	
MPPT Range (Full Load)	200–425 VDC	250–425 VDC
MPPT Tracker/Strings	2	
Max. Continuous PV Input Current	20 ADC × 2	
Isc PV	25 ADC × 2	
Max. Backfeed Current	0 ADC	
Max. Continuous PV Input Power	7,200 W	10,000 W

9.4 Grid Terminal Input / Output

	E3.68KS-D22	E5KS-D22
Rated Voltage	230 VAC	
Rated Frequency	50 Hz	
Maximum Continuous Input Current	32 A	40 A
Maximum Continuous Input Power	7,360 W	9,200 W
Rated Output Current	16 A	21.7 A
Maximum Continuous Output Current	16.7 A	22.7 A
Power factor (Cos phi), Adjustable	0.8 leading–0.8 lagging	
Rated Output Power	3,680 W	5,000 W
Maximum Continuous Output Apparent Power	3,680 VA	5,000 VA
Grid Port Overcurrent Protection	63 A	
Maximum Short Circuit Current Rating	100 A	

9.5 EPS Load Terminal Output

	E3.68KS-D22	E5KS-D22
Rated Voltage	230 VAC	
Rated frequency	50 Hz	
Rated Output Current	16 A	21.7 A
Maximum Continuous Output Current	16 A	21.7 A
Rated Continuous Output Power	3,680 W	5,000 W
Maximum Output Apparent Power	3,680 VA	5,000 VA
EPS Load Overcurrent Protection	32 A	

9.6 Battery Pack

Battery specification	BP48100P1A-G2	BP48100PF1A-G2
------------------------------	----------------------	-----------------------

normal	Battery capacity		5.12 kWh		
	Battery type		LFP		
	Rated voltage		51.2V		
	Operating voltage range		44.8–57.6V		
Operations	Maximum charging current		80A (0.8C)		
	Maximum discharging current		80A (0.8C)		
	Operating temperature range	Charge	0°C~+50°C	-10°C~+50°C	
		Discharge	-10°C~+50°C		
	Storage temperature range		0°C~+35°C		
	Relative humidity		0%~95%(No condensation)		
	Protective class		I		
	Short circuit ratings		360A 300us		
BMS	Maximum number of batteries		Maximum 4 batteries in parallel		
	Monitored item		System voltage, current, battery voltage, battery temperature, PCBA temperature measurement		
	Communication mode		CAN		
	Ventilation mode		Passive and active cooling		
Physical parameters	Weight (kg)		50.5		
	Size (W×H×D) mm		725*165*370(Excluding handles)		
	Water resistance level		IP65		
Reference to standards		IEC 62619 IEC 62477 IEC 62040 IEC61000-6-1//3 UN38.3			

10 Quality Assurance

When product faults occur during the warranty period, his partner will provide free service or replace the product with a new one.

Evidence

During the warranty period, the customer shall provide the product purchase invoice and date. In addition, the trademark on the product shall be undamaged and legible. Otherwise, company has the right to refuse to honor the quality guarantee.

Conditions

After replacement, unqualified products shall be processed by company.

The customer shall give company or his partner a reasonable period to repair the faulty device.

Exclusion of Liability

In the following circumstances, company has the right to refuse to honor the quality guarantee:

The free warranty period for the whole machine/components has expired.

The device is damaged during transport.

The device is incorrectly installed, refitted, or used.

The device operates in harsh environment, as described in this manual.

The fault or damage is caused by installation, repairs, modification, or disassembly performed by a service provider or personnel not from company or his authorized partner.

The fault or damage is caused by the use of non-standard or company.

Components or software.

The installation and use range are beyond stipulations of relevant international standards.

The damage is caused by unexpected natural factors.

For faulty products in any of above cases, if the customer requests maintenance, paid maintenance service may be provided based on the judgment of company.

11 Abbreviations

A

AC	Alternating Current
AFCI	Arc-Fault Circuit-Interrupter
App	Application
AWG	American Wire Gauge

B

BESS	Battery Energy Storage System
BMS	Battery Management System

C

CT	Current Transformer
----	---------------------

D

DC	Direct Current
DOD	Depth of Discharge
DRED	Demand Response Enabling Device
DRM	Demand Response Mode
DSP	Digital Signal Processor

E

EMI	Electromagnetic Interference
EMS	Energy Management System
BACK UP	Emergency Power Supply

G

GFCI	Ground Fault Circuit Interrupter
------	----------------------------------

I

ISO	Insulation
-----	------------

M

MPPT	Maximum Power Point Tracker
------	-----------------------------

P

PV	Photovoltaic
----	--------------

R

RCD	Residual Current Device
RESP	Response
RRCR	Radio Ripple Control Receiver

S

SCI	Serial Communication Interface
SOC	State of Charge

12 Appendix: Definition of DVC

Decisive voltage Classification (DVC)	Limits of working voltage V		
	a.c. voltage r.m.s. U_{ACL}	a.c. voltage peak U_{ACPL}	d.c. voltage mean U_{DCL}
A*	25 (16)	35.4 (22.6)	60 (35)
B	50 (33)	71 (46.7)	120 (70)
C	> 50 (> 33)	> 71 (> 46.7)	> 120 (> 70)

The table values in parentheses are to be used for PCE or portions of PCEs rated for installation in wet locations as addressed in 6.1 for environmental categories and minimum environmental conditions.
*DVC-A circuits are allowed under fault conditions to have voltages up to the DVC- B limits, for maximum 0.2 s.